

**BOARD OF TRUSTEES
UNIVERSITY OF THE DISTRICT OF COLUMBIA
UDC RESOLUTION NO. 2025 - 23**

SUBJECT: APPROVAL OF CHANGE ORDER NO. 6 TO CONTRACT NO. GF-2020-C-0036 TO CONSTRUCT A NEW ATHLETIC FIELD ON THE VAN NESS CAMPUS BY AND BETWEEN CONSYS, INC. AND THE BOARD OF TRUSTEES OF THE UNIVERSITY OF THE DISTRICT OF COLUMBIA (“CONTRACT”)

WHEREAS, in accordance with the D.C. Official Code § 38-1202.01(a)(8), the Board of Trustees (“Board”) is charged with the responsibility of governing the University of the District of Columbia (“University”) and possesses all the powers necessary or convenient to make contracts and procure and contract for goods and services; and

WHEREAS, pursuant to 8B DCMR § 3000.4, specific approval of the President is required for contracts totaling two hundred fifty thousand dollars (\$250,000.00) or more; and

WHEREAS, pursuant to 8B DCMR § 205.4(e), specific authorization of the Board is required for any commitment greater than one million dollars (\$1,000,000.00) in a single fiscal year for certain University procurements; and

WHEREAS, in accordance with the D.C. Official Code §1-204.51(b)(1), approval of the Council of the District of Columbia (“Council”) is required for all contracts involving expenditures in excess of one million dollars (\$1,000,000.00) during a twelve (12)-month period; and

WHEREAS, in Resolution No. 2020-54, the Board approved the Contract for Consys, Inc. (“Contractor”) to construct a new athletic field in the total amount of four million one hundred forty-four thousand nine hundred seventy-six dollars and eighty cents (\$4,144,976.80); and

WHEREAS, the University executed four (4) change orders, Change Order Nos. 1 – 4, in the total amount of nine hundred seventy-seven thousand six hundred eight dollars and fifty-eight cents (\$977,608.58); and

WHEREAS, in Resolution No. 2024-11, the Board approved Change Order No. 05, in the total amount of one million two hundred fifty-nine thousand one hundred eight dollars one cent (\$1,259,108.01) additional security cameras, replacement of the damaged south walk, improved drainage at Building 47, major modifications to the field’s ADA access ramp due to unforeseen conditions and other enhancements to the field; and

WHEREAS, the University desires to add additional modifications to the scope of work to relocate the emergency vehicle access, increase the new turf field size, and to address unforeseen conditions that were beyond the Contractor’s control; and

**BOARD OF TRUSTEES
UNIVERSITY OF THE DISTRICT OF COLUMBIA
UDC RESOLUTION NO. 2025 - 23**

WHEREAS, the services and equipment for Change Order No. 6 will increase the cost of the Contract by one million five hundred thirty-one thousand six hundred fifty-two dollars and seventy-one cents (\$1,531,652.71) for a total amount of seven million nine hundred thirteen thousand three hundred forty-six dollars and ten cents (\$7,913,346.10); and

WHEREAS, the President has approved the modification of the Contract; and

WHEREAS, the Board has reviewed the terms of the Contract modification, as well as all necessary certifications from the University Administration, and is satisfied that the proposed Change Order No. 6 to the Contract represents the proper culmination of the University's due diligence process and represents the best value to the University.

NOW THEREFORE BE IT RESOLVED, that, subject to the required approval of the Council, the Board approves Change Order No. 6 to the Contract and each the President and the University's Chief Contracting Officer are authorized to execute the Contract modification in substantially the form attached hereto as **Attachment A**.

BE IT FURTHER RESOLVED, that as soon as practicable, the President is hereby directed to transmit the Contract modification to the Council for its approval.

Approved by the Executive Committee:

June 24, 2025



Warner H. Session
Chairperson of the Board

Solicitation No. GF-2020-C-0036
Replace Natural Grass Field with Synthetic Turf

Table of Contents		Pages
1	Change Order	2 - 3
2	Contractor's Proposal	4 - 147
3	BCD 001 Request for Proposal	148 - 152
4	Insurance Certificates	153 - 157
5	Performance & Payment Bonds	158- 164
6	Certificate of Clean Hands	164 - 166



**UNIVERSITY OF THE DISTRICT OF COLUMBIA
OFFICE OF THE VICE PRESIDENT FOR
FACILITIES AND REAL ESTATE MANAGEMENT**

CONSTRUCTION CONTRACT CHANGE ORDER REQUEST

Change Order No. 06	Contract No. GF-2020-C-0036	Project No.	Date 04/10/2025
-------------------------------	---------------------------------------	--------------------	---------------------------

Consys, Inc.
2502 Martin Luther King Jr. Ave., SE
Washington, DC 20020

Reference: n/a FWA No.(s): N/A
Letter (s): N/A
Proposal Request No.(s): BCD-01

Dear Mr. Kasimsetty,

In accordance with Article(s) 3. CHANGES within the Standard Contract Provision of your Construction contract for the "Replace Natural Grass Field with Synthetic Turf" project. The following change has been ordered. Execute the work in accordance with the enclosed Description of Change dated April 10, 2025.

It is mutually agreed that in exchange for this modification and other considerations, the contractor hereby releases the Board of Trustees of the University of the District of Columbia (University"), without any reservations, from any and all actual or potential claims and demands for delays and disruptions, additional work which the contractor, or any person claiming by through or under the contractor, may now have, or may now have, or may in the future have against the University, for, by reason of, or in any number, based on or upon or growing out of or in any manner connected with the subject modification or the prosecution of the work hereunder.

FOR ACCOMPLISHING THE FOREGOING

The contract price is hereby:

Original Contract Amount	\$	4,144,976.80
Change Order No. 1	\$	486,510.51
Change Order No. 2	\$	109,837.38
Change Order No. 3	\$	82,105.19
Change Order No. 4	\$	299,155.50
Change Order No. 5	\$	1,259,108.01
Change Order No. 6	\$	<u>1,531,652.71</u>
New Contract Amount	\$	7,913,346.10

The contract period of performance is hereby:

Extended	<u>426</u>	Calendar Days
Reduced	<u>0</u>	Calendar Days

Adjusted Period of Performance: 958 Calendar Days

Accepted as Complete Compensation:

Vijay Kasimsetty

Contractor

Recommended:

Alan Walsh

Alan Walsh
Contract Administrator
Capital Planning and Construction Division

Approved:

Mary Ann Harris, Chief Contracting Officer or
Eddie Whitaker, Contracting Officer
Contracting and Procurement

Sign and Return to Capital Procurement Division (CPD)



**UNIVERSITY OF THE DISTRICT OF COLUMBIA
OFFICE OF THE VICE PRESIDENT FOR
FACILITIES AND REAL ESTATE MANAGEMENT**

CONSTRUCTION CONTRACT CHANGE ORDER REQUEST

Description of Change

Project Name: "Replace Natural Grass Athletic Field with Synthetic Turf"
Contract No. GF-2020-C-0036
Contractor: Consys, Inc.
Subject: Change Order No. 06

The Contractor's proposal to provide the following:

<u>CLIN</u>	<u>DESCRIPTION</u>	<u>LUMP SUM PRICE</u>
	1. Athletic Field Additional Requirements	\$ 1,531,652.71
	TOTAL	\$ 1,531,652.71



CONTRACT NO.: GF-2020-C-0036

PROJECT NAME: UDC – Replace Natural Grass Athletic Field with Synthetic Turf

ATTACHMENT A - BCD 1 - Back-up

2502 Martin Luther King Junior Avenue, SE Washington, DC 20020
Office: (202) 545-1333; Fax: (202) 545-1339; e-mail: consys@consys-inc.net
www.consys-inc.net



Construction Estimate

Project: GF-2020-C-0036, Replacement of the Natural Grass Athletic Field Synthetic Turf - BCD 1

Item No.	Description	Estimate	Remarks
1	Additional Erosion & Sediment Control (PCR 2)	\$ 12,938.06	
2	Synthetic Turf Surface Area Increase (PCR 3)	\$ 236,518.37	
3	Site Drainage Difference (Bid Vs Permit Drawings - PCR 19)	\$ 151,695.39	
4	Site Storage, Silt Fence, Construction Entrance (PCR 20)	\$ 64,796.40	
5	Haul Spoils (PCR 21)	\$ 106,216.88	
6	Drinking Water Line (PCR 22)	\$ 71,939.11	
7	F & Install Top Soil and Sodding Athletic Field (DOEE) (PCR 23)	\$ 22,256.00	
8	New Emerg Vehicle Access Ramp at Southeast Location (PCR 25)	\$ 129,245.33	
9	Sand Bedding - (PCR 26)	\$ 3,498.38	
10	Additional Concrete Curb (RFI 31 Response - PCR 27)	\$ 47,614.94	
11	Additional Work Unidentified Concrete Structures (PCR 28)	\$ 31,162.50	
12	Chain Linke Fence Fabric & Gauge (RFI 30 - PCR 29)	\$ 9,414.63	
13	NW Vehicle Access Ramp Concrete Work (PCR 30)	\$ 148,578.47	
14	ADA Ramp Rework (RFI 041 - PCR 31)	\$ 80,549.01	
15	Geothermal Piping Repairs (042624 - PCR 32)	\$ 118,685.51	
16	F & I Seed and Straw Adjacent Staging Area (PC R 33 - DOEE)	\$ 24,907.50	
17	Synthetic Turf Accelaration (PCR 34)	\$ 169,744.54	
18	Chain Linke Fence Posts & Panels (PCR 35)	\$ 3,777.13	
19	Additional Mesh Screens (ADA Ramp - PCR 36)	\$ 19,267.15	
20	Turf Grooming Equipment and Netting (PCR 37)	\$ 34,064.85	
21	Field Signage (PCR 38)	\$ 3,493.68	
22	Shelter Wheel Kit (PCR 39)	\$ 3,657.04	
23	Additional Wall Padding (South Wall - PCR 41)	\$ 37,631.84	
24			
25			
	TOTAL	\$ 1,531,652.71	

Note: 1. The above proposal is valid as a lump sum and breakdown of individual task is for informational purposes only.

2. Equipment includes dump truck, dump fees, hauling costs, power tools such as saws, air compressors, safety equipment, hand tools, wheel barrows etc. (as applicable to the job).

3. Labor rates include labor burden including Worker's Comp. Ins., Other Ins., FICA, Unemployment etc.

EXCLUSIONS: SEE COVER LETTER

PRICE QUALIFICATION : Because of current supply chain challenges, most construction products are subject to delayed delivery times and unusual price volatility due to conditions that are beyond of the General Contractor. Currently, we are unable to procure any future price obligations from the various subcontractors and manufacturers. As a result, we are unable to offer any price protection for this job. The pricing presented are based upon current material costs, which are subject to change at any time. CONSYS, Inc is doing their best to mitigate these issues, but we can't be held responsible for the cost or material delivery impacts that are beyond our control. If there is an increase in the cost of the products



CONTRACT NO.: GF-2020-C-0036

PROJECT NAME: UDC – Replace Natural Grass Athletic Field with Synthetic Turf

ATTACHMENT A - BCD 1 Back-up – Item No. 1

2502 Martin Luther King Junior Avenue, SE Washington, DC 20020
Office: (202) 545-1333; Fax: (202) 545-1339; e-mail: consys@consys-inc.net
www.consys-inc.net



August 15, 2022

VIA e-mail: eddie.whitaker@udc.edu
mgadson@udc.edu

Mr. Eddie Whitaker
Contracting Officer
The University of the District of Columbia
Office of Strategic Sourcing & Procurement
4200 Connecticut Avenue, NW
Building 39, Suite 200C
Washington, DC 20008

Re: Contract No. GF-2020-C-0036 – Replace Natural Grass Athletic Field with Synthetic Turf – PCR 2 -
Additional Erosion & Sediment Control Measures

Mr. Whitaker:

Consys, Inc. hereby submits this PCR for having to complete the below mentioned work for a firm lump sum price of \$12,938.06.

SCOPE OF WORK:

- Provide Super Silt fence as per DCRA Permit drawings
- Final clean-up of our area of work

We respectfully request you to review this PCR and issue us a necessary change order for this added work that has to be performed.

EXCLUSIONS:

- All permits and any utility deposit
- All mechanical, electrical, plumbing, sprinkler, architectural, FFE, access control and voice & data work
- All hazmat work

We, thank you once again for providing us the opportunity to submit this proposal. Our proposal is valid for a period of 30 days.

Consys, Inc. is a CBE & MDOT-MBE certified company.

If you need any further clarification, feel free to contact the undersigned at (202) 439-4123.

Sincerely,

Vijay R. Kasimsetty
Vice President

Cc: Joanna Edwards, Alan Walsh, COTR and File

732 Kennedy Street, NW Washington, DC 20011
Office: (202) 545-1333; Fax: (202) 545-1339; e-mail: consys@consys-inc.net
www.consys-inc.net



Construction Estimate

Project: GF-2020-C-0036, RNgAFwST - PCR 2 - Additional Eroison & Sediment Control

Item No.	Description	Unit	Quantity	Material	Material Costs	Labor Rate	Hours	Labor Costs	Equipment	Line Total	Subcontractor	Remarks
1	Super Silt Fence	Job		\$ 1,398.00	\$ -			\$ -		\$ -	\$11,475.00	DCRS Permitt Drawing Change
2					\$ -			\$ -		\$ -		
3					\$ -			\$ -		\$ -		
4					\$ -			\$ -		\$ -		
5					\$ -			\$ -		\$ -		
6					\$ -			\$ -		\$ -		
7					\$ -			\$ -		\$ -		
8					\$ -			\$ -		\$ -		
9					\$ -			\$ -		\$ -		
10					\$ -			\$ -		\$ -		
SUBTOTAL										\$ -	\$ 11,475.00	
OH @ 10%										\$ -	\$ -	
PROFIT @ 10%										\$ -	\$ 1,147.50	
SUB TOTAL										\$ -	\$ 12,622.50	
BOND & INSURANCE COST										\$ -	\$ 315.56	
TOTAL										\$ -	\$ 12,938.06	
GRAND TOTAL										\$	12,938.06	

1. The above proposal is valid as a lump sum and breakdown of individual task is for informational purposes only.

2. Equipment includes dump truck, dump fees, hauling costs, power tools such as saws, air compressors, safety equipment, hand tools, wheel barrows etc. (as applicable to the job).

3. Labor rates include labor burden including Worker's Comp. Ins., Other Ins., FICA, Unemployment etc.

4. EXCLUSIONS: SEE COVER LETTER

5. PRICE QUALIFICATION : Because of current supply chain challenges, most construction products are subject to delayed delivery times and unusual price volatility due to conditions that are beyond of the General Contractor. Currently, we are unable to procure any future price obligations from the various subcontractors and manufacturers. As a result, we are unable to offer any price protection for this job. The pricing presented are based upon current material costs, which are subject to change at any time. CONSYS, Inc is doing their best to mitigate these issues, but we can't be held responsible for the cost or material delivery impacts that are beyond our control. If there is an increase in the cost of the products between when the project is bid and when the work is performed, the amount of the contract may increase to reflect the additional costs being incurred. If product delivery issues or material increases occur, we will provide proper notification and documentation to support any claims submitted.



University of District of Columbia Athletic Field - North REVISED 1

Consys, Inc.
E2951

Vijay Kasimsetty
vijay@consys-inc.net
8/2/2022

Muller, Inc.
400 N Washington St, 3rd Floor, Falls Church, VA 22046
O: 703-560-4040 F: 571-500-4847
estimating@mullerrec.com
www.mullerrec.com

About Us

Muller Erosion & Site Services, Inc. is one of the largest and most resourceful site construction businesses in the Mid-Atlantic.

Where We Work: The entire Mid-Atlantic including DC, MD, VA, WV, PA, & DE

Who We Work For: Site Development/Heavy Highway/Infrastructure Contractors, General Contractors, Real Estate Developers, Government Agencies, Homebuilders and Property Managers

Equipment We Own: Combination Sewer Cleaners, Jet Vac trucks, Flush/Water Trucks, Hydroexcavators, CCTV equipment, Loaders & Compact Loaders, Excavators & Mini Excavators, Hydroseeders, Strawblowers, Dump Trucks, Trenchers, Street Sweepers, Dozers

EROSION CONTROL

- Super Silt Fence & Silt Fence
- Hydroseeding
- Temporary Seed & Straw/Mulching
- Slope Stabilization
- Matting/Blanket Installation
- Wash Racks & Construction Entrances
- Inlet/Outlet/Outfall

STORMWATER MAINTENANCE

- Maintenance on all Stormwater/BMPs
- Jet Vac Trucks
- Muck out Ponds
- Drainage Repairs
- Stormwater Vault & Filter Cleaning
- Pipe Cleaning
- Flush Trucks
- Completion of Maintenance Reports
- Annual Maintenance

MISCELLANEOUS SITE SERVICES

- Hydroexcavating
- Tree Protection/Safety Fence
- Jet Vac Trucks/Flush Trucks/CCTV
- Dump Trucks/Water Trucks
- Root Pruning
- Bobcat/Mini Excavator Services
- Grading & Fine Grading
- Street Sweeping

BOND RELEASE

- Wet Utility Punch Work
- Sidewalk/Curb Remove and Replace
- Sidewalk/Curb Installation
- Asphalt Patching & Asphalt Crack Hot Sealing
- Landscaping Pruning and Replacement
- Top Soil & Sod Installation

STORMWATER INSTALLATION

- Stormwater Facility/BMP Installation:
- Value Engineering on All BMPS
- Underdrain Install on VDOT/MDOT/DDOT Jobs
- Storm Pipe Installation
- Pond Lining/Baffle Board/Gabion Basket
- Downspout Drainage Systems

STORMWATER INSPECTIONS & REPAIRS

- CCTV
- Pipe and Structure Patching/Parging
- Pipe Lining
- Pipe Repairs & Dig Ups
- Drainage/Washout/Sinkhole Repairs
- PE Sealed Inspection Certifications
- PE Sealed As-Built Certifications

25. Maintenance of storm flow. Including dewatering, diversion, pump around, ground water/natural spring conflicts, or similar.
 26. Locating or damage to private or unmarked utilities.
 27. Utility conflicts, relocation, test pitting, capping, abandonment, or removal. Excludes all coordination with utility companies for shutoff or continuation of utility services.
 28. Mulch/mat/stone access. Rehab of any potential access points is excluded.
 29. Demolition or replacement of features not specifically mentioned. Any sections of sidewalk, curb/gutter, or similar that are deemed in poor condition but not included as removal or replacement are excluded.
 30. Backfilling for all concrete or asphalt work.
 31. Monitoring of existing buildings or structures. Prior, during, or post-construction. Muller shall not be held liable for any damage to existing dwellings or structures. Subsurface or surface.
 32. Mechanical, motorized, or hydraulic equipment that may be needed to remove a manhole or structure lid, door, grate, etc. to gain access.
 33. All work relating to traffic control/lighting conduit, cables/detection devices, irrigation, or similar.
 34. All necessary demolition or clearing of asphalt, concrete, woody debris, construction materials, or similar which interfere with Muller's work shall be completed (by others) prior to Muller's mobilization.
- B. All pricing is subject to change 30 days after proposal date.
 - C. For all projects which exceed a 12-month duration past the date of this proposal, Muller reserves the right to add a minimum of 3.00% in escalation and for each subsequent year thereafter.
 - D. If any If any material cost increases in excess of "Project Material Threshold" or fuel cost increases beyond "baseline price" occur from time of proposal through end of project (related to tasks needed to complete scope of work on this project), a change order may be issued from Muller to client.
 - E. All minimum mobilization quantities must be continuous and immediately available upon our crew's arrival to the site.
 - F. Unless noted in our proposal, all work is to be installed per field rep of client. Not per plan.
 - G. All pricing assumes our trucks, equipment, and employees have access to immediate working area. We reserve the right to bill client for additional time spent transporting materials and completing work due to lack of access.
 - H. Time spent relocating to other work areas and any loading and/or unloading time associated with relocation(s) may result in downtime being billed on a T&M basis.
 - I. For any situations where a daily job ticket is provided by Muller to a client representative (whether by e-mail, mail, or in person), all F&I measurements and all T&M labor hours/material quantities/equipment hours provided within the daily job ticket are deemed accurate and approved. Whether the ticket is signed or not. Unless client responds in writing outlining the disagreement within 48 hours of receipt of the ticket.
 - J. Muller will e-mail all project daily job tickets to client and ticket quantities/items shall be deemed 100% approved for payment per rates included within this proposal (or per Muller standard rates if previously not provided) if nothing is disputed by client within 48 hours of sent time of e-mail. The only method for client to dispute quantities on daily job tickets is by e-mailing both the Muller Project Manager and Sean Philbrick at sphilbrick@mullerec.com within 48 hours of time e-mail is sent by Muller.
 - K. Muller bears no responsibility, liability, contractual or financial exposure for any supervision, labor, other overhead that the client, or any other party, has on-site. If work cannot be performed due to any fault of Muller at any time, no back charges of any kind to Muller shall occur and Muller shall have no liability whatsoever.
 - L. In the event that any suit or action is instituted under or in relation to this Agreement, including without limitation to enforce any provision in this Agreement, the prevailing party in such dispute shall be entitled to recover from the losing party all fees, costs and expenses of enforcing any right of such prevailing party under or with respect to this Agreement, including without limitation, such reasonable fees and expenses of attorneys and experts, which shall include, without limitation, all fees, costs and expenses of appeals.
 - M. Muller does not guarantee and will not be held liable for any schedule dates or completion dates communicated to client or client's project team for any and all services provided due to numerous variables out of Muller's hands.
 - N. Client agrees that any amount not paid within 30 days of invoice date will carry interest at the rate of 1.5% per month, both before and after judgement, and further agrees to pay all costs incurred in collection, including attorney's fees in the amount of 1/3 of the total balance due if this account is placed with an attorney for collection, whether suit is filed or not. If client does not sign Muller's proposal, Muller reserves the right to add/modify terms & conditions during contract review.
 - O. For all extra work that client directs Muller to complete (that is not within above referenced scope of work section), Muller will bill the client on a T&M basis unless a separate agreement is reached for additional scope of work prior to the work beginning.
 - P. Client expressly agrees to submit to personal jurisdiction in VA and agrees that the forum for any litigation pursuant to this agreement or any other contract between Muller and client, whether Muller or client brings suit, shall be the County of Fairfax, Virginia. This agreement shall be governed by and construed in accordance with the laws of Virginia.
 - Q. Muller shall have no obligation to begin or continue performance until adequate credit and funding information is provided on request of client.
 - R. Client shall make a careful inspection at the time of delivery.
 - S. Client's failure to give written notice specifying any claim within ten (10) days of delivery shall constitute an unqualified acceptance of the labor and material delivered and a waiver of all claims.
 - T. Muller will not be liable for any damage, warranty, or remedy and back charges will not be accepted without prior written notification specifying any defect, an opportunity to view and repair, replace or otherwise cure, and approval by Muller.
 - U. Client agrees that all funds owed to Client from anyone or received by Client relating to materials supplied by Muller shall be held in trust for the benefit of Muller, to the extent that sums are justly due to Muller under this Agreement. Client agrees it has no interest in Trust Funds held by anyone, to segregate and make no use of, except to promptly

pay Muller.

- V. Muller to be paid monthly for work in place.
- W. FORCE MAJEURE. Neither Party will be liable for any failure or delay in performing an obligation under this Agreement that is due to any of the following causes (which causes are hereinafter referred to as "Force Majeure"), to the extent beyond its reasonable control: acts of God, accident, riots, war, terrorist act, epidemic, pandemic (including the Covid-19 pandemic), quarantine, civil commotion, breakdown of communication facilities, breakdown of web host, breakdown of internet service provider, natural catastrophes, governmental acts or omissions, changes in laws or regulations, national strikes, fire, explosion, or generalized lack of availability of raw materials or energy.

Time and Material (T&M) Work

- A. For all T&M/rental work, unless otherwise noted, we will bill our clients two-way travel time and all equipment to be billed the entire time on-site. Whether being actively used or not. Dispatch location from Muller's yard at 9460 Hawkins Drive, Manassas, VA. Muller crews leave our yard at 5:45am. Time spent waiting upon arrival to site will be billed.
- B. For all T&M/rental work: any and all downtime, including but not limited to downtime due to client direction or waiting on information to begin or continuing working shall not be deducted from any billable hours. Additionally, Muller crews may take a reasonable lunch break (30 minutes or less) and this time shall not be deducted from billable hours.

Excavation, Trenching, and Grading

- A. Excludes compaction/geotechnical testing or coordination, proof rolling, design/engineering services, shop drawings, or any guaranteed testing results.
- B. Excludes excavation of rock, roots, asphalt/concrete, debris, overly compacted earth, stiff clay, saturated soils, or similar. Unclassified excavation is excluded. Assumes all work occurs in normal working conditions and all cut is deemed clean, dry, and stackable.
- C. Proctor material requirements are excluded.
- D. Unless noted otherwise, excludes off-site export of any excavated or net-excess material. If fill material is required, assumes all material may be flipped from cut material.
- E. Undercutting is excluded. Assumes subgrade is suitable for fill & compaction.
- F. Excludes grading to specific tolerances, or subbase preparation within specific tolerances for permanent features i.e. asphalt, concrete, etc. Regardless of specifications, tolerances shall not exceed +/- 0.2'.

Silt Fence and Other Fence or Perimeter Control Types

- A. All fence installation pricing assumes a mini excavator may be used and installation is continuous. Price is subject to change for non-continuous installation.
- B. Excludes hand trenching, post driving, or similar work for any fence installation.
- C. Stabilization of trench lines parallel to installation from trenching is excluded.
- D. Layout requiring trucks or equipment to traverse across site areas (currently stabilized or not) excludes regrading or stabilizing due to access requirements.

Seeding, Mulching, Sodding, and Root Pruning

- A. Seed germination and survivability rate is not guaranteed. Unless the below qualifications are met.
 - 1. Topsoil samples are test and approved by Muller prior to seeding.
 - 2. Maintenance watering is included in Muller's pricing.
 - Regardless of what is included, pricing does not guarantee a certain percentage of grass growth or establishment.
- B. Excludes: soil inspection/testing, topsoiling/amendments, seedbed preparation, lime incorporation into the soil, watering, maintenance, or warranty.
- C. Straw mulch is excluded unless specifically stated. Otherwise mulching will consist of fiber mulch with tack. Seed mix will be applied as a homogeneous slurry. Separate applications are excluded.
- D. All hydroseeding and seeding/mulching unit pricing assumes a minimum of (2.00) continuous acres (unless noted otherwise) is available per mobilization and that areas are accessible by hydroseeder and strawblower. Otherwise we reserve the right to bill on a T&M basis.
- E. Muller Erosion Mix for temporary or permanent seeding assumes all seeding materials and hydraulic mulch may be mixed and applied homogeneously as a slurry and through a single pass of the application area. Price is subject to change if hydraulic mulch must be applied independently. All pricing excludes straw mulch unless otherwise noted.
- F. All hydroseeding/tacking pricing assumes there is a water source available on-site. Additional fees will apply if MESS needs to travel off site for a water source.
- G. All seed and straw work completed by hand may be billed on a T&M basis.
- H. For all VDOT and applicable state highway seeding; pricing assumes seed, lime, and fertilizer are all being applied as a homogenous slurry via the hydroseeding method.
- I. VDOT seeding unit prices do not stand alone. All pricing assumes seed, lime, and fertilizer are applied during all mobilizations. Prices are subject to change if any mix components are removed or modified from VDOT standard application rates.
- J. For all VDOT, applicable state highway projects, or other projects requiring lime application in excess of (200) LBS/AC, lime application assumes dry form material is an acceptable alternate to pelletized or agricultural lime. (75) LBS/AC of dry form is included for every (1.00) TN/AC specified.
- K. Muller is not responsible for structures, materials, vehicles, or similar that may get seed materials on them if left in the area during seed application.
- L. Sod installation excludes grading, topsoil work, eradication of existing vegetation, soil amendments/fertilizing, watering (other than initial), warranty, or maintenance.
- M. All root pruning shall be performed without the supervision or implementation of a certified arborist.
- N. Root pruning shall be conducted utilizing a walk behind trencher or cut wheel attachment. Spoils (if applicable) shall be left on-site & parallel to trench.
- O. Root pruning excludes topsoil backfill, spoils removal, hand pruning, wood chip/mulch mats, watering, root burlap wrapping, tree wound dressing, tunneling/boring, trench

- C. Root pruning excludes topsoil backfill, spoils removal, hand pruning, wood chip/mulch mats, watering, root burlap wrapping, tree wound dressing, tumbling/boring, trench lining, air knife work, or similar.

Bioretention/SWM Facility

- A. Unless otherwise noted, all bioretention/SWM facility pricing excludes:
 - 1. Excavation, export of any materials, fine grading, tilling/ripping, dewatering, maintenance due to weather events, mulch/mat/stone access, rehab of potential access points, erosion controls (at any stage of construction), impermeable/clay liner, geotextile liner, Nyloplast/overflow basins, concrete core drilling, double washed stone, topsoil stripping/import/re-spread, signage, plantings/landscaping, seeding/matting, concrete work, inspections testing/as-built survey, general maintenance/warranty, or anything not specifically identified as an inclusion.
- B. Assumes a sufficient stockpile area is available within 30 feet of install area, area is at proposed subgrade elevation (when excavated by others), area is at proposed final surface elevation (when excavated by Muller), area is stabilized upon mobilization, and spoils have been removed by others.
- C. Pond side slopes shall be stabilized by others.
- D. Excludes repair work to or accepting any responsibility for any damaged curb/gutter, concrete, or asphalt that may occur from construction of stormwater BMP facilities.
- E. Assumes immediate work area is accessible to on-road trucking for material deliveries.
- F. Assumes facility is being built in the correct sequence. Otherwise we cannot be held responsible for any failures or issues with facility as a result of constructing out of sequence.
- G. Assumes we are awarded all facilities within the proposal and all may be built at the same time (one mobilization for all facilities) unless otherwise specified.
- H. Pricing is only per plan view sheets and typical section provided.
- I. For all drainage pipe in bioretention facilities, we assume 0.5% slope is required unless otherwise noted on the bioretention detail provided by client.
- J. Warranty is excluded in our installation of facilities due to facilities being designed and specified by others.
- K. Regardless of whether the plans or any project related literature specifies double washed stone, pricing does not include double washed stone unless specifically referenced in proposal.

Post-Construction Stormwater Maintenance

- A. Proposal is provided for routine maintenance only. All non-routine maintenance or repairs identified through inspections or otherwise noted, are excluded and will be billed additional. Pricing excludes all materials other than what is specifically identified.
- B. Traffic control is excluded. Assumes work areas may be secured using standard cones only.
- C. While drainage issues may be present, the proposed work does not guarantee any change to drainage. Positive, negative, or static.
- D. Completion of work does not guarantee acceptance by private, local, state, or other jurisdictions/agencies.
- E. Cartridge exchanges assume existing cartridges are in acceptable condition for return shipment & acceptance by the manufacturer. Additional fees may apply if cartridges are damaged.
- F. Annual or recurring fees are not guaranteed for any specific period and are subject to change. Muller will notify client in advance of any price changes.

Underdrain and Storm Drain

- A. Unless otherwise noted, all underdrain pricing excludes:
 - 1. trenching into rock/asphalt/concrete/soil-cement, utility conflicts, removal of existing underdrain, all grading, hauling away or relocation of any spoils, loading spoils into trucks or loader bucket, installing cleanouts, core drilling, parging structure connections, or repairs to any damaged (caused by others) pipe originally installed by Muller after time of installation.
- B. Line item pricing for installation excludes CCTV inspection. Separate line item pricing may be provided for CCTV inspection.
 - A. Pricing assumptions;
 - B. We have an area to stockpile stone within 25 yards of our direct work area.
 - C. Compaction will be completed with bobcat/skid steer and mini excavator without the use of a roller or plate tamper.
 - D. Area is delivered at finished grade and all trenching occurs in common earth or loose stone.
 - E. Trenching is only to be performed per dimensions specified in proposal, or by detail if no dimension is noted in proposal. All additional excavation and subsequent backfill above and beyond these trench dimensions may be charged extra.
 - F. All trenching shall follow the existing grade (as prepared by others) and be dug at a constant depth. Muller shall not be responsible for adjusting grade, smoothing or undercutting for "waves", or similar. Boring under utilities, duct banks, and similar is excluded.
 - G. Assumes stakeout or layout (via paint markings by client) for any and all underdrain/endwalls/pipe/structures, is provided by client. Our price does NOT include stakeout or layout. Assumes client provides all survey/stakeout, as requested by Muller. All installation areas, cleanouts, directional flow, and similar shall be staked. Muller shall install per field layout and client direction. If layout is insufficient or incorrect, Muller shall not be held liable.
 - H. Assumes work sequence allows Muller to maintain a minimum of (14) LF unobstructed working width. Measured from whichever side any machines are working on. Work sequence and width shall allow Muller's machines to fully turn and dump directly into the trench.
 - I. Assumes all trenches may be dug straight on i.e. not from the sides.
 - J. Assumes all stone placement & grading for median, sidewalk, or similar applications may be accomplished using a mini excavator or skid steer. Hand raking or grading

- J. Assumes all stone placement & grading for median, sidewalk, or similar applications may be accomplished using a mini excavator or skid steer. Hand raking or grading is excluded.
- K. UD-4 pricing assumes width of excavation no more than 12" and depth of excavation no more than 12".
- L. All outlet pipe pricing assumes width of excavation no more than 18" and depth of excavation no more than 3'.
- M. Placing stone below pipe is excluded. Assumes all pipe may be laid directly on fabric/subgrade and stone backfilled over pipe to the top of trench.
- C. Unless otherwise specified, all UD pricing excludes any and all parging and core drilling at structures. Regardless of any specifications concerning item being installed.
- D. Minimum mobilizations associated with UD is for UD work only. Underdrain must be continuous and must be all available upon arrival of our crews to the job site.
- E. All underdrain pricing which excludes stone placement above trench i.e. trench only and without median/drainage blanket/sidewalk stone: fabric is included for trench dimensions only.

Jet/Vac, CCTV, and Hydro Excavation

- A. Unless otherwise noted, the following is excluded:
 - 1. Dump fees or off-site disposal.
 - 2. Demolition or replacement of impervious surfaces i.e. asphalt, concrete, or similar.
 - 3. Stabilization of work areas.
 - 4. Pipeline Assess and Certification Program (PACP) certified inspection/analysis and report submissions.
 - 5. Root cutting or removal of foreign debris that standard jetting may not remove i.e. concrete, asphalt, rock, etc.
 - 6. Ground water conflicts.
 - 7. Removal of any potentially hazardous materials. If known hazardous materials are on or near Muller's work area client shall notify Muller, in writing, prior to mobilization.
 - 8. Sewage vacuuming, hauling, or disposal.
- B. All T&M work shall be billed port to port. Dispatch location from Muller's yard at 9460 Hawkins Drive, Manassas, VA.
- C. For all District of Columbia work, client agrees to provide an on-site water source/meter and grant unrestricted access. Client agrees to pay all water consumption charges and fees.
- D. For all F&I and Lump Sum work, assumes a water source is available on-site.
- E. It is the client's responsibility to provide a clear list of all runs and structures they want cleaned and inspected. If the exact pipe runs & structure ID's are not indicated and provided by the client, Muller cannot guarantee acceptance for any cleaning or CCTV inspection.
- F. For all CCTV inspections, client shall provide a structure identification list and provide clear written direction of all pipe runs requiring inspection. Downtime shall be billed on a T&M basis for any F&I or Lump Sum pricing.
- G. If Muller is contracted to perform pipe jetting or cleaning but is not contracted to inspect the same pipe segments, Muller shall not be held responsible for any pass/fail designations. The same applies for vice versa situations.
- H. Combination Jet/Vac Truck and CCTV (Mainline) includes a (2) man crew only. Unless noted otherwise.
- I. Compaction for all backfill cannot be guaranteed.
- J. Assumes direct access (within 8') to all work areas and all manhole lids are operational.
- K. F&I and Lump Sum pricing assumes single pipe entry & exits at structure locations.
- L. For all pipe 48" diameter or less, proposal assumes pipe is no more than 5% full of any debris, at any single point along the pipe run.
- M. For all pipe greater than 48" diameter, proposal assumes pipe is no more than 2% full of any debris, at any single point along the pipe run.
- N. For jetting projects, jetting is included as light and shall not exceed (3) passes through any given run. Hose length is approximately (500) LF. Runs exceeding this distance are subject to reduced cleaning efforts by means of residual water flow only.
- O. For all structures which may be included for vacuuming/sediment removal, assumes debris material does not exceed a 12" depth at the bottom of the structure.
- P. CCTV inspection assumes pipe segments at any point during inspection do not require crack measuring in excess of (5) EA per (200) LF.
- Q. Test pitting via hydro excavation shall be neat cut to the greatest extent possible. Tolerances shall not exceed 2" in any direction as excavation commences downward. If any excavation areas result in base or sidewall material failing & additional work required, downtime & materials may be billed on a T&M basis.
- R. Prior to Muller's mobilization, each test pit location shall be field marked (by others). If utilities are not uncovered at marked locations, additional charges shall be billed for each additional test pit.
- S. Unless noted otherwise, test pit depths are limited to a maximum depth of (6.00) VF. If any test pit depths exceed this depth, each additional foot may be billed a minimum amount of \$85.00 per vertical foot. This rate is subject to change on all non-private jobs or projects with wage scale requirements.
- T. When completing test pits or pot holing services, the Lump Sum fee provided includes only the number of test pits stated within proposal unless specifically stated otherwise. If one of these test pits is unable to locate the identified service, and Muller believes it is beneficial to client to locate the service, Muller reserves the right to bill client for additional test pits on a per each basis for all test pits above and beyond number included within proposal. Pricing for additional test pits to be determined by taking total lump sum fee and dividing by number of test pits proposed.
- U. For all projects which are bond release or punch work related and Muller is repairing an underground pipe or structure, the client is responsible for confirming the repair

Signature _____

Date: _____

Acceptance of Proposal - By signing below you are agreeing to the above prices and Muller Erosion is authorized to perform the work as specified.

Customer/Client:

Authorized Signature _____

Date: _____

Billing Information

Billing Entity (If Applicable) _____

Billing Address

Street Address _____

City, State, Zip Code _____

Preferred Billing Method(s)

- E-mail to Project Manager
- E-mail to Accounts Payable
- Hard Copy by Mail

Project Manager Contact Information

Name: _____ Phone: (_____ E-mail: _____

Accounts Payable Contact Information

Name: _____ Phone: (_____ E-mail: _____

Purchase Order Number _____

Special Conditions of Invoice _____



CONTRACT NO.: GF-2020-C-0036

PROJECT NAME: UDC – Replace Natural Grass Athletic Field with Synthetic Turf

ATTACHMENT A - BCD 1 Back-up – Item No. 2

2502 Martin Luther King Junior Avenue, SE Washington, DC 20020
Office: (202) 545-1333; Fax: (202) 545-1339; e-mail: consys@consys-inc.net
www.consys-inc.net



August 15, 2022

VIA e-mail: eddie.whitaker@udc.edu
mgadson@udc.edu

Mr. Eddie Whitaker
Contracting Officer
The University of the District of Columbia
Office of Strategic Sourcing & Procurement
4200 Connecticut Avenue, NW
Building 39, Suite 200C
Washington, DC 20008

Re: Contract No. GF-2020-C-0036 – Replace Natural Grass Athletic Field with Synthetic Turf – PCR 3 - Synthetic Turf Surface Area Increase

Mr. Whitaker:

Consys, Inc. hereby submits this PCR for having to complete the below mentioned work for a firm lump sum price of **\$236,518.37.**

SCOPE OF WORK:

- Artificial synthetic surface area increase
- Final clean-up of our area of work

We respectfully request you to review this PCR and issue us a necessary change order for this added work that has to be performed.

EXCLUSIONS:

- All permits and any utility deposit
- All mechanical, electrical, plumbing, sprinkler, architectural, FFE, access control and voice & data work
- All hazmat work

We, thank you once again for providing us the opportunity to submit this proposal. Our proposal is valid for a period of 30 days.

Consys, Inc. is a CBE & MDOT-MBE certified company.

If you need any further clarification, feel free to contact the undersigned at (202) 439-4123.

Sincerely,

Vijay R. Kasimsetty
Vice President

Cc: Joanna Edwards, Alan Walsh, COTR and File

732 Kennedy Street, NW Washington, DC 20011
Office: (202) 545-1333; Fax: (202) 545-1339; e-mail: consys@consys-inc.net
www.consys-inc.net



Construction Estimate

Project: GF-2020-C-0036, RNgAFwST - PCR 3 - Synthetic Turf Surface Area Increase

Item No.	Description	Unit	Quantity	Material	Material Costs	Labor Rate	Hours	Labor Costs	Equipment	Line Total	Subcontractor	Remarks
1	Additional synthetic surface area increase	Job	8512	\$ 18.47	\$ 157,216.64	\$ 115.00	305	\$ 35,075.00		\$ 192,291.64		
2					\$ -			\$ -		\$ -		
3					\$ -			\$ -		\$ -		
4					\$ -			\$ -		\$ -		
5					\$ -			\$ -		\$ -		
6					\$ -			\$ -		\$ -		
7					\$ -			\$ -		\$ -		
8					\$ -			\$ -		\$ -		
9					\$ -			\$ -		\$ -		
10					\$ -			\$ -		\$ -		
SUBTOTAL										\$ 192,291.64	\$ -	
OH @ 10%										\$ 19,229.16	\$ -	
PROFIT @ 10%										\$ 19,229.16	\$ -	
SUB TOTAL										\$ 230,749.97	\$ -	
BOND & INSURANCE COST										\$ 5,768.75	\$ -	
TOTAL										\$ 236,518.72	\$ -	
GRAND TOTAL										\$	236,518.72	

1. The above proposal is valid as a lump sum and breakdown of individual task is for informational purposes only.

2. Equipment includes dump truck, dump fees, hauling costs, power tools such as saws, air compressors, safety equipment, hand tools, wheel barrows etc. (as applicable to the job).

3. Labor rates include labor burden including Worker's Comp. Ins., Other Ins., FICA, Unemployment etc.

4. EXCLUSIONS: SEE COVER LETTER

5. PRICE QUALIFICATION : Because of current supply chain challenges, most construction products are subject to delayed delivery times and unusual price volatility due to conditions that are beyond of the General Contractor. Currently, we are unable to procure any future price obligations from the various subcontractors and manufacturers. As a result, we are unable to offer any price protection for this job. The pricing presented are based upon current material costs, which are subject to change at any time. CONSYS, Inc is doing their best to mitigate these issues, but we can't be held responsible for the cost or material delivery impacts that are beyond our control. If there is an increase in the cost of the products between when the project is bid and when the work is performed, the amount of the contract may increase to reflect the additional costs being incurred. If product delivery issues or material increases occur, we will provide proper notification and documentation to support any claims submitted.



CONTRACT NO.: GF-2020-C-0036

PROJECT NAME: UDC – Replace Natural Grass Athletic Field with Synthetic Turf

ATTACHMENT A - BCD 1 Back-up – Item No. 3

2502 Martin Luther King Junior Avenue, SE Washington, DC 20020
Office: (202) 545-1333; Fax: (202) 545-1339; e-mail: consys@consys-inc.net
www.consys-inc.net



August 18, 2024

VIA e-mail: eddie.whitaker@udc.edu
mgadson@udc.edu

Mr. Eddie Whitaker
Contracting Officer
The University of the District of Columbia
Office of Strategic Sourcing & Procurement
4200 Connecticut Avenue, NW
Building 39, Suite 200C
Washington, DC 20008

Re: Contract No. GF-2020-C-0036 – Replace Natural Grass Athletic Field with Synthetic Turf – PCR 19 - Site Drainage Difference

Mr. Whitaker:

Consys, Inc. hereby submits this PCR for having to complete the below mentioned work for a firm lump sum price of \$151,695.39.

SCOPE OF WORK:

- Additional Subsurface drainage due to changes from bid drawings to DCRA Approved drawings
- Final clean-up of our area of work

We respectfully request you to review this PCR and issue us a necessary change order for this added work that has to be performed.

EXCLUSIONS:

- All permits and any utility deposit
- All mechanical, electrical, plumbing, sprinkler, architectural, FFE, access control and voice & data work
- All hazmat work

We, thank you once again for providing us the opportunity to submit this proposal. Our proposal is valid for a period of 30 days.

Consys, Inc. is a CBE & MDOT-MBE certified company.

If you need any further clarification, feel free to contact the undersigned at (202) 439-4123.

Sincerely,

Vijay R. Kasimsetty
Vice President

Cc: Joanna Edwards, Alan Walsh, COTR and File

732 Kennedy Street, NW Washington, DC 20011
Office: (202) 545-1333; Fax: (202) 545-1339; e-mail: consys@consys-inc.net
www.consys-inc.net



Construction Estimate

Project: GF-2020-C-0036, RNgAFwST - PCR 19 - Site Drainage Difference

Item No.	Description	Unit	Quantity	Material	Material Costs	Labor Rate	Hours	Labor Costs	Equipment	Line Total	Subcontractor	Remarks
1	Additional Excavation for 8" line	Job	1		\$ -	\$ 95.00		\$ -	\$ 3,500.00	\$ 3,500.00		In-house
2	Additional Perimeter 8" line (925lf)	Job	925	\$ 16.00	\$ 14,800.00	\$ 95.00	90	\$ 8,550.00		\$ 23,350.00		In-house
3	Sand bedding for 8" line (925lf)	Job	1	\$ 4,500.00	\$ 4,500.00	\$ 95.00	80	\$ 7,600.00		\$ 12,100.00		In-house
4	Additional subsurface drainage 4" (2749lf)	Job	1		\$ -			\$ -		\$ -	\$68,725.00	See attached e-mail
5	Haul Spoils	CY	128	\$ 50.00	\$ 6,400.00			\$ -	\$ 4,400.00	\$ 10,800.00		In-house
6	Survey and Layout	Job	1		\$ -			\$ -		\$ -	\$2,500.00	2 additional trips @1,250.00 per trip
7	Coredrill for water line	Job	1		\$ -	\$ 65.00	16	\$ 1,040.00	\$ 350.00	\$ 1,390.00		In-house
8					\$ -			\$ -		\$ -		
9					\$ -			\$ -		\$ -		
10	Submittals & Shopdrawings	Job	1		\$ -	\$ 135.00	40	\$ 5,400.00		\$ 5,400.00		
11	Senior Project Manager	Hrs			\$ -			\$ -		\$ -		
12	Project Manager	Hrs			\$ -			\$ -		\$ -		
13	Project Superintendent	Hrs			\$ -			\$ -		\$ -		
14	Project Engineer	Hrs			\$ -			\$ -		\$ -		
15	Skilled Laborer	Hrs			\$ -			\$ -		\$ -		
16	Unskilled Laborer	Hrs			\$ -			\$ -		\$ -		
17	Dumpster / Trash Disposal	Job			\$ -			\$ -	\$ 1,500.00	\$ 1,500.00		
18	Final clean-up	Job			\$ -			\$ -		\$ -		
SUBTOTAL										\$ 58,040.00	\$ 71,225.00	
OH @ 10%										\$ 5,804.00	\$ -	
PROFIT @ 10%										\$ 5,804.00	\$ 7,122.50	
SUB TOTAL										\$ 69,648.00	\$ 78,347.50	
BOND & INSURANCE COST										\$ 1,741.20	\$ 1,958.69	
TOTAL										\$ 71,389.20	\$ 80,306.19	
GRAND TOTAL										\$	151,695.39	

1. The above proposal is valid as a lump sum and breakdown of individual task is for informational purposes only.

2. Equipment includes dump truck, dump fees, hauling costs, power tools such as saws, air compressors, safety equipment, hand tools, wheel barrows etc. (as applicable to the job).

3. Labor rates include labor burden including Worker's Comp. Ins., Other Ins., FICA, Unemployment etc.

4. EXCLUSIONS: SEE COVER LETTER

5. PRICE QUALIFICATION : Because of current supply chain challenges, most construction products are subject to delayed delivery times and unusual price volatility due to conditions that are beyond of the General Contractor. Currently, we are unable to procure any future price obligations from the various subcontractors and manufacturers. As a result, we are unable to offer any price protection for this job. The pricing presented are based upon current material costs, which are subject to change at any time. CONSYS, Inc is doing their best to mitigate these issues, but we can't be held responsible for the cost or material delivery impacts that are beyond our control. If there is an increase in the cost of the products between when the project is bid and when the work is performed, the amount of the contract may increase to reflect the additional costs being incurred. If product delivery issues or material increases occur, we will provide proper notification and documentation to support any claims submitted.

Monday, July 15, 2024 at 19:22:01 Eastern Daylight Time

Subject: RE: Athletic Field - Lines and Logos - Full Submittal
Date: Wednesday, March 1, 2023 at 9:55:38 AM Eastern Standard Time
From: Yoos, Jeff
To: Talay, Victoria, Vijay R Kasimsetty
CC: Burnham, Maggie

Attachments: image001.jpg, image002.jpg, image003.jpg, image004.jpg, image005.jpg, image007.jpg, image008.jpg, image009.jpg, image010.jpg, image011.jpg, image015.jpg, image016.jpg, image017.jpg, image018.jpg, image019.jpg, image021.jpg, image022.jpg, image023.jpg, image024.jpg, image025.jpg, image027.jpg, image028.jpg, image029.jpg, image030.jpg, image031.jpg, image032.jpg, image033.jpg, image034.jpg, image035.jpg, image036.jpg, image038.jpg, image039.jpg, image040.jpg, image041.jpg, image042.jpg, image047.png, image046.jpg, image048.jpg, image049.jpg, image050.jpg, image051.jpg, image052.jpg, image053.jpg, image054.jpg, image055.jpg, image056.jpg

There is additional 4" perf pipe – 2749' @ \$ 25/LF = \$ 68,725.00 additional cost beyond our current scope.

Also – the mainline perimeter drain is 8" that was being installed by someone else so they should note the as well – 925' or so.

We will need to connect to that 8" pipe so they need to install the "T" fittings for each tie in that we need to make. They should also have them marked.

Thanks,

Jeff

Jeff Yoos
Regional Director Operations



THE ULTIMATE
SURFACE EXPERIENCE



FieldTurf
2555 Washington Rd. Suite 630
Pittsburgh PA 15241
USA

Tel: [+1 412-835-7060](tel:+14128357060)
Mobile: [+1 412-475-3339](tel:+14124753339)
Fax: [+1 412-835-7063](tel:+14128357063)
IM: jeff.yoos@external.tarkett.com
Email: jeff.yoos@external.fieldturf.com

CONFIDENTIALITY NOTICE: This e-mail message is intended only for the above-mentioned recipient(s). Its content is confidential. If you have received this e-mail by error, please notify us immediately and delete it without making a copy, nor disclosing its content, nor taking any action based thereon. Thank you. <http://www.tarkett.com/e-mail-disclaimer.htm>

From: Talay, Victoria <Victoria.Talay@fieldturf.com>



CONTRACT NO.: GF-2020-C-0036

PROJECT NAME: UDC – Replace Natural Grass Athletic Field with Synthetic Turf

ATTACHMENT A - BCD 1 Back-up – Item No. 4

2502 Martin Luther King Junior Avenue, SE Washington, DC 20020
Office: (202) 545-1333; Fax: (202) 545-1339; e-mail: consys@consys-inc.net
www.consys-inc.net



December 08, 2023

VIA e-mail: eddie.whitaker@udc.edu
mgadson@udc.edu

Mr. Eddie Whitaker
Contracting Officer
The University of the District of Columbia
Office of Strategic Sourcing & Procurement
4200 Connecticut Avenue, NW
Building 39, Suite 200C
Washington, DC 20008

Re: Contract No. GF-2020-C-0036 – Replace Natural Grass Athletic Field with Synthetic Turf – PCR 20 - Site Storage, Silt Fence, Construction Entrance

Mr. Whitaker:

Consys, Inc. hereby submits this PCR for having to complete the below mentioned work for a firm lump sum price of **\$64,796.40.**

SCOPE OF WORK:

- F & Install additional construction entrance at Vane Ness entrance
- Material storage and handling of synthetic surface offsite
- F & Install additional silt fence for new staging area (DOEE requirement)
- F & Install security fence around new storage area
- Remove and regrade construction entrance at Van Ness entrance
- Final clean-up of our area of work

We respectfully request you to review this PCR and issue us a necessary change order for this added work that has to be performed.

EXCLUSIONS:

- All permits and any utility deposit
- All mechanical, electrical, plumbing, sprinkler, architectural, FFE, access control and voice & data work
- All hazmat work

We, thank you once again for providing us the opportunity to submit this proposal. Our proposal is valid for a period of 30 days.

Consys, Inc. is a CBE & MDOT-MBE certified company.

If you need any further clarification, feel free to contact the undersigned at (202) 439-4123.

Sincerely,

Vijay R. Kasimsetty
Vice President

Cc: Joanna Edwards, Alan Walsh, COTR and File

732 Kennedy Street, NW Washington, DC 20011
Office: (202) 545-1333; Fax: (202) 545-1339; e-mail: consys@consys-inc.net
www.consys-inc.net



Construction Estimate

Project: GF-2020-C-0036, RNgAFwST - PCR 20 - Site Storage, Silt Fence, Construction Entrance

Item No.	Description	Unit	Quantity	Material	Material Costs	Labor Rate	Hours	Labor Costs	Equipment	Line Total	Subcontractor	Remarks
1	Field turf storage and Handling	Job	1		\$ -			\$ -		\$ -	\$10,747.00	See Attached Quote
2	Additional construction entrance	job	1		\$ -			\$ -		\$ -	\$16,313.00	See Attached Quote
3	Additional silt fence	job	1	\$ 3,000.00	\$ 3,000.00	\$ 55.00	80	\$ 4,400.00		\$ 7,400.00		DOEE Requirement - staging area
4	Additional site security fence	job	1	\$ 3,500.00	\$ 3,500.00			\$ -		\$ 3,500.00		UDC PSD Request
5	Remove and regrade construction entrance	Job	1		\$ -	\$ 65.00	80	\$ 5,200.00	\$ 3,500.00	\$ 8,700.00		
6	Surveying	Job	1		\$ -						\$1,500.00	One trip at \$1,500.00
7												
8	Submittals & Shopdrawings	Job	1		\$ -	\$ 135.00	40	\$ 5,400.00		\$ 5,400.00		
9	Senior Project Manager	Hrs			\$ -			\$ -		\$ -		
10	Project Manager	Hrs			\$ -			\$ -		\$ -		
11	Project Superintendent	Hrs			\$ -			\$ -		\$ -		
12	Project Engineer	Hrs			\$ -			\$ -		\$ -		
13	Skilled Laborer	Hrs			\$ -			\$ -		\$ -		
14	Unskilled Laborer	Hrs			\$ -			\$ -		\$ -		
15	Dumpster / Trash Disposal	Job			\$ -			\$ -	\$ 1,500.00	\$ 1,500.00		
16	Final clean-up	Job			\$ -			\$ -		\$ -		
SUBTOTAL										\$ 26,500.00	\$ 28,560.00	
OH @ 10%										\$ 2,650.00	\$ -	
PROFIT @ 10%										\$ 2,650.00	\$ 2,856.00	
SUB TOTAL										\$ 31,800.00	\$ 31,416.00	
BOND & INSURANCE COST										\$ 795.00	\$ 785.40	
TOTAL										\$ 32,595.00	\$ 32,201.40	
GRAND TOTAL										\$ 64,796.40		

1. The above proposal is valid as a lump sum and breakdown of individual task is for informational purposes only.

2. Equipment includes dump truck, dump fees, hauling costs, power tools such as saws, air compressors, safety equipment, hand tools, wheel barrows etc. (as applicable to the job).

3. Labor rates include labor burden including Worker's Comp. Ins., Other Ins., FICA, Unemployment etc.

4. EXCLUSIONS: SEE COVER LETTER

5. PRICE QUALIFICATION : Because of current supply chain challenges, most construction products are subject to delayed delivery times and unusual price volatility due to conditions that are beyond of the General Contractor. Currently, we are unable to procure any future price obligations from the various subcontractors and manufacturers. As a result, we are unable to offer any price protection for this job. The pricing presented are based upon current material costs, which are subject to change at any time. CONSYS, Inc is doing their best to mitigate these issues, but we can't be held responsible for the cost or material delivery impacts that are beyond our control. If there is an increase in the cost of the products between when the project is bid and when the work is performed, the amount of the contract may increase to reflect the additional costs being incurred. If product delivery issues or material increases occur, we will provide proper notification and documentation to support any claims submitted.

Contract Change Order Proposal



Date: July 21, 2023

COP#: 1

From: FieldTurf USA, Inc.
7445 Côte-de-Liesse Road, Suite 200
Montreal, Quebec H4T 1G2

To: CONSYS, Inc.
732 Kennedy St. NW
Washington, DC 20011

Project: UDC Soccer Lacrosse Field
4200 Connecticut Ave NW
Washington, DC 20008

Contact: Vijay Kasimsetty, Vice President
Phone: 202-545-1333

Ref: 88010310

Fax:
Email: vijay@consys-inc.net

Scope Description:

- Storage of EcoGrind infill at third party warehouse due to turf installation delay: \$2,000 per month
- Moving infill to the job site, labor: \$300 per load x 6 loads
- Equipment rental: \$330 per day x 2 days
- Freight: \$895 per truck x 6 trucks
- OH&P 10%

DESCRIPTION	QTY	UNIT	UP	PRICE
Storage per month	1	EA	2000.00	\$2,000.00
Labor to move infill from warehouse to the job site	6	EA	300.00	\$1,800.00
Equipment Rental	2	EA	300.00	\$600.00
Freight	6	EA	895.00	\$5,370.00
SUBTOTAL				\$9,770.00
FieldTurf OH&P	1	LS	977.00	\$977.00

TOTAL CHANGE ORDER: \$10,747.00

Notes/Exclusions:

- Quote is valid for thirty (30) calendar days
- The Contract Time will be increased by 0 days.

It is mutually agreed that for the above-referenced changes to take place, the original contract price will be adjusted by the above-referenced amount, which will become payable in accordance with the same terms and conditions as in the original contract or purchase order.

If all the terms of this change order are acceptable please have an authorized representative sign the bottom of this document and return it to FieldTurf's Montreal office, or as otherwise provided in the contract documents. FieldTurf will, in turn, provide a fully executed copy for your records. Once this document is fully executed, it will be considered a revision/modification to the original contract or purchase order.

FieldTurf USA, Inc.

Owner/General Contractor

Authorized Representative

Authorized Representative

Date

Date

PROPOSAL

RODGERS BROTHERS SERVICE

2230 Lawrence Ave, NE
Washington, DC 20018
(202)526-0274 • (240) 377-0566 FAX

PROPOSAL NO. 1

SHEET NO. _____

DATE April 29, 2023

PROPOSAL SUBMITTED TO:

Consys, Inc.
732 Kennedy Street, NW
Washington, DC 20011

WORK TO BE PERFORMED AT:

UDC-Athletic Field
Washington, DC 20018

We have visited the site and are familiar with the building. We hereby propose to furnish labor, materials, and equipment necessary to perform the following scope of work:

Install approximately 600 lf of standard DC Spec silt fence at the perimeter of the adjacent vacant lot along the east & southern perimeter of the lot. Install a SCE with a wash rack per the attached sketch.: \$16,313.00

Add/Alt: Install an additional 70 lf of access road: \$3,500

Exclusions: Permits

All material is guaranteed to be as specified, and the above work to be performed in accordance with the drawings and specifications submitted for the above work and completed in a substantial workmanlike manner for the sum stipulated above.

Respectfully submitted: _____

By: Sean K. Carney, Project Executive

Any alteration or deviation from above specifications involving extra costs will be executed only upon written order and will become an extra charge over and above the estimate. All agreements are contingent upon strikes, accidents or delays beyond our control.

ACCEPTANCE PROPOSAL

The above prices, specifications and conditions are satisfactory and are hereby accepted. You are authorized to do the work as specified. Payments will be made as outlined above.

Signature _____

Date _____

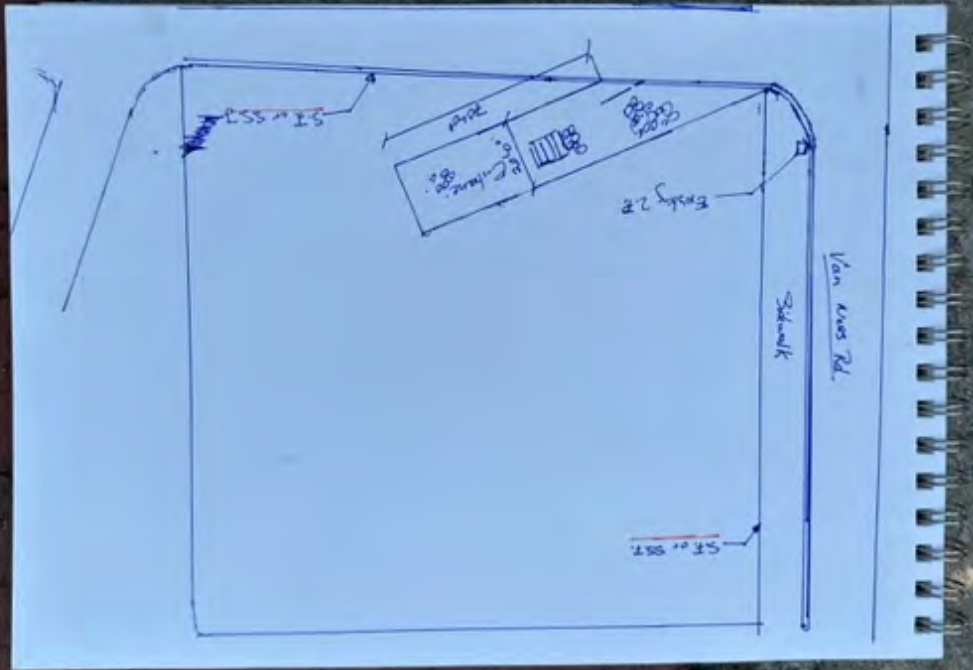

Saturday, January 6, 2024 at 13:09:05 Eastern Standard Time

Subject: Re: [EXTERNAL] FW: Parking Notice (UDC Field)
Date: Saturday, January 6, 2024 at 1:07:58 PM Eastern Standard Time
From: Sleith, Lisa
To: Vijay R Kasimsetty
CC: Ronald Alvarenga, Chris Marshall, Khanna, Surinder, Walsh, Alan

Yes, go ahead, please.

Lisa
Sent from my iPhone

On Jan 6, 2024, at 12:57PM, Vijay R Kasimsetty <vijay@consys-inc.net> wrote:

EXTERNAL: This email was sent to you from an external source. Please review the content carefully and open attachments or click links only if you recognize the sender.

GA Lisa:

As discussed yesterday, we have been requested by UDC – PSD to post the attached signs due to a few intrusion events that have occurred on campus.

Please confirm this is acceptable and approved.

We will also be installing a temporary fence along Van Ness so access to UDC is restricted.

Feel free to call or e-mail me if needed.

Thank You,

Vijay R. Kasimsetty

Vice President
CONSYS, Inc.

P: (202) 545-1333
E: vijay@consys-inc.net

PLEASE MAKE NOTE WE HAVE MOVED TO OUR NEW OFFICE LOCATED AT 2502 MARTIN LUTHER KING JUNIOR AVENUE, SE WASHINGTON DC 20020.

“USE BEST PRACTICES & BE SAFE”

Confidentiality notice: This electronic message and any attachment(s) are confidential and may be subject to the attorney/client privilege and/or work product immunity. This email is only for the use of the intended recipient(s). If you have received this e-mail in error, please notify the sender immediately by replying to this e-mail, then delete this message and any attachment(s) from your system. Be advised that computer viruses may be transmitted via email. Recipients should check all email and attachments for the presence of viruses. Accordingly, the sender does not accept liability for any errors, corruption or damage that arise as a result of this e-mail transmission.

From: Ronald Alvarenga <ronald.alvarenga@consys-inc.net>

Date: Friday, January 5, 2024 at 1:22 PM
To: Vijay R Kasimsetty <vijay@consys-inc.net>
Subject: Fwd: Parking Notice (UDC Field)

FYI

Thank you,

Ronald Alvarenga
Project Manager

Consys, INC
P: 202-545-1333
C: 202-439-8123
F: 202-545-1339

Begin forwarded message:

From: "Jimenez-Menendez, Anthony" <anthony.jimenezmenen@udc.edu>
Date: January 5, 2024 at 1:11:14 PM EST
To: Ronald Alvarenga <ronald.alvarenga@consys-inc.net>, Chris Marshall <chris.marshall@consys-inc.net>, "Simon, Senai" <senai.simon@udc.edu>
Subject: Parking Notice (UDC Field)

Please,

feel free to print as many documents as needed.

+

This email is regarding:

Due to parking concerns @ the UDC Field and Services Lanes located next to Van Ness St. N.W. & Building #41, the following documents were generated to assist with any arising inquiries on the matter.

Please familiarize yourself with the attached documents, so, if contacted regarding these matters, we can refer inquiries to the listed Consys Inc. Superintendent & Project Manager.

Sergeant : Menendez #104
Email: Anthony.Jimenezmenen@udc.edu
Cell: 202-308-2958
University of the District of Columbia Police Department
4200 Connecticut Ave. N.W.

Building #39 | Room C04
Washington, DC 20008
UDC Police: 202-274-5050
Fax: 202-274-7486

*****LAW ENFORCEMENT SENSITIVE*****

CAUTION: This e-mail (including attachments) is covered by the Electronic Communications Privacy Act, Title 18 United States Code 2510-2521, is confidential and may be legally privileged. This message may contain law enforcement sensitive information. Do not disseminate, which includes forwarding the contents of this message, without the approval of the sender. If you are not the addressee, you may not copy or deliver it to anyone else or use it in any unauthorized manner. To do so is prohibited and may be unlawful. If you receive this e-mail by mistake, advise the sender immediately by using the reply feature in your e-mail client.

<Field Maintenance & Contractor Parking ONLY.docx>
<CONTRACTOR VEHICLE Window Display.docx>



CONTRACT NO.: GF-2020-C-0036

PROJECT NAME: UDC – Replace Natural Grass Athletic Field with Synthetic Turf

ATTACHMENT A - BCD 1 Back-up – Item No. 5

2502 Martin Luther King Junior Avenue, SE Washington, DC 20020
Office: (202) 545-1333; Fax: (202) 545-1339; e-mail: consys@consys-inc.net
www.consys-inc.net



March 23, 2025.

VIA e-mail: eddie.whitaker@udc.edu
mgadson@udc.edu

Mr. Eddie Whitaker
Contracting Officer
The University of the District of Columbia
Office of Strategic Sourcing & Procurement
4200 Connecticut Avenue, NW
Building 39, Suite 200C
Washington, DC 20008

Re: Contract No. GF-2020-C-0036 – Replace Natural Grass Athletic Field with Synthetic Turf – PCR 21 - Haul Spoils

Mr. Whitaker:

Consys, Inc. hereby submits this PCR for having to complete the below mentioned work for a firm lump sum price of **\$106,216.88**

SCOPE OF WORK:

- Haul unsuitable spoils
- Final clean-up of our area of work

We respectfully request you to review this PCR and issue us a necessary change order for this added work that has to be performed.

EXCLUSIONS:

- All permits and any utility deposit
- All mechanical, electrical, plumbing, sprinkler, architectural, FFE, access control and voice & data work
- All hazmat work

We, thank you once again for providing us the opportunity to submit this proposal. Our proposal is valid for a period of 30 days.

Consys, Inc. is a CBE & MDOT-MBE certified company.

If you need any further clarification, feel free to contact the undersigned at (202) 439-4123.

Sincerely,

Vijay Kasimsetty

Vijay R. Kasimsetty
Vice President

Cc: Joanna Edwards, Alan Walsh, COTR and File

2502 Martin Luther King Junior Avenue, SE Washington, DC 20020
Office: (202) 545-1333; Fax: (202) 545-1339; e-mail: consys@consys-inc.net
www.consys-inc.net



Construction Estimate

Project: GF-2020-C-0036, RNgAFwST - PCR 21 Haul Spoils

Item No.	Description	In-House	Subcontractor	Remarks
1	Equipment for unsuitable soils		\$ 67,215.00	See attached invoice from subcontractor
2	Haul unsuitable spoils		\$ 27,200.00	See attached invoice from subcontractor
3				
4				
5				
6				
7				
8				
9				
10				
11				
12				
13				
14				
15				
16				
17				
18				
19				
20				
21				
	Sub-Total	\$ -	\$ 94,415.00	
	OH	\$ -	\$ -	
	Profit	\$ -	\$ 9,441.50	
	Bonds & Insurance	\$ -	\$ 2,360.38	
	TOTAL	\$ -	\$ 106,216.88	
	GRAND TOTAL	\$	\$ 106,216.88	

Note: 1. The above proposal is valid as a lump sum and breakdown of individual task is for informational purposes only.

2. Equipment includes dump truck, dump fees, hauling costs, power tools such as saws, air compressors, safety equipment, hand tools, wheel barrows etc. (as applicable to the job).

3. Labor rates include labor burden including Worker's Comp. Ins, Other Ins., FICA, Unemployment etc.

EXCLUSIONS: SEE COVER LETTER

PRICE QUALIFICATION : Because of current supply chain challenges, most construction products are subject to delayed delivery times and unusual price volatility due to conditions that are beyond of the General Contractor. Currently, we are unable to procure any future price obligations from the various subcontractors and manufacturers. As a result, we are unable to offer any price protection for this job. The pricing presented are based upon current material costs, which are subject to change at any time. CONSYS, Inc is doing their best to mitigate these issues, but we can't be held responsible for the cost or material delivery impacts that are beyond our control. If there is an increase in the cost of the products between when the project is bid and when the work is performed, the amount of the contract may increase to reflect the additional costs being incurred. If product delivery issues or material increases occur, we will provide proper notification and documentation to support any claims submitted.

**RODGERS BROTHERS SERVICE,
INC.**

POST OFFICE BOX 41545
WASHINGTON, DC 20018
+13013227131

BILL TO
CONSYS, INC.
POST OFFICE BOX 60825
WASHINGTON, DC 20039

SHIP TO
CONSYS, INC.
4200 CONNECTICUT AVENUE,
N.E.
WASHINGTON, D.C. 20002

INVOICE 39584

DATE 09/13/2024 **TERMS** Due on receipt

DATE	DESCRIPTION	QTY	RATE	AMOUNT
09/13/2024	***UDC ATHLECTIC FIELD - LABOR AND EQUIPMENT: 3/6/24 - 8/26/24***			
	FOREMAN	99	55.00	5,445.00
	LABORER	442	45.00	19,890.00
	EQUIPMENT -MINI-EXCAVATOR	146	180.00	26,280.00
	EQUIPMENT - JUMPING JACK	96	70.00	6,720.00
	EQUIPMENT - EXCAVATOR	40	222.00	8,880.00

Contact RODGERS BROTHERS SERVICE, INC. to pay.
PLEASE PAY UPON RECEIPT.
THANK YOU FOR YOUR BUSINESS!

SUBTOTAL 67,215.00
TAX 0.00
TOTAL 67,215.00

TOTAL DUE \$67,215.00

RODGERS BROTHERS SERVICE,
INC.
POST OFFICE BOX 41545
WASHINGTON, DC 20018
+13013227131

BILL TO
CONSYS, INC.
POST OFFICE BOX 60825
WASHINGTON, DC 20039

SHIP TO
ANTELOPE LANE
CAPITOL HEIGHTS, MD

INVOICE 39486

DATE 05/13/2024 **TERMS** Due on receipt

SHIP DATE
05/10/2024

DATE	DESCRIPTION	QTY	RATE	AMOUNT
05/10/2024	TKT #159726 - TRK #63 - LOAD OF DIRT	1	400.00	400.00
	TKT #159724 - TRK #63 - LOAD OF DIRT	1	400.00	400.00
	TKT #160168 - TRK #63 - LOAD OF DIRT	1	400.00	400.00
	TKT #160169 - TRK #63 - LOAD OF DIRT	1	400.00	400.00
	TKT #159113 - TRK #64 - LOAD OF DIRT	1	400.00	400.00

PLEASE PAY UPON RECEIPT.
THANK YOU FOR YOUR BUSINESS!

SUBTOTAL	2,000.00
TAX	0.00
TOTAL	2,000.00
TOTAL DUE	\$2,000.00

Type text here

Mr. Vijay
HOC

RECEIVED
6/6/24

RODGERS BROTHERS SERVICE,
INC.
POST OFFICE BOX 41545
WASHINGTON, DC 20018
+13013227131

BILL TO
CONSYS, INC.
POST OFFICE BOX 60825
WASHINGTON, DC 20039

SHIP TO
ANTELOPE LANE
CAPITOL HEIGHTS, MD

INVOICE 39484

DATE 05/10/2024 TERMS Due on receipt

SHIP DATE
05/09/2024

SHIP VIA
4200 CONN. AVE., NW - WASH.DC

DATE	DESCRIPTION	QTY	RATE	AMOUNT
05/09/2024	TKT #159729 - TRK #62 - LOAD OF DIRT	1	400.00	400.00
	TKT #159731 - TRK #62 - LOAD OF DIRT	1	400.00	400.00
	TKT #159732 - TRK #62 - LOAD OF DIRT	1	400.00	400.00
	TKT #159654 - TRK #63 - LOAD OF DIRT	1	400.00	400.00
	TKT #159655 - TRK #63 - LOAD OF DIRT	1	400.00	400.00
	TKT #159656 - TRK #63 - LOAD OF DIRT	1	400.00	400.00
	TKT #159400 - TRK #64 - LOAD OF DIRT	1	400.00	400.00
	TKT #159361 - TRK #64 - LOAD OF DIRT	1	400.00	400.00
	TKT #159110 - TRK #64 0 LOAD OF DIRT	1	400.00	400.00

PLEASE PAY UPON RECEIPT.
THANK YOU FOR YOUR BUSINESS!

SUBTOTAL 3,600.00
TAX 0.00
TOTAL 3,600.00

TOTAL DUE \$3,600.00

Mr. Vijay
UOC

RECEIVED
6/6/24

RODGERS BROTHERS SERVICE,
INC.
POST OFFICE BOX 41545
WASHINGTON, DC 20018
+13013227131

BILL TO
CONSYS, INC.
POST OFFICE BOX 60825
WASHINGTON, DC 20039

SHIP TO
ANTELOPE LANE
CAPITOL HEIGHTS, MD

INVOICE 39463

DATE 04/26/2024 TERMS Due on receipt

SHIP DATE
04/25/2024

SHIP VIA
4200 CONN., AVE. NW - WASH., DC

DATE	DESCRIPTION	QTY	RATE	AMOUNT
04/25/2024	TKT #158001 - TRK #62 - LOAD OF DIRT	1	400.00	400.00
	TKT #159714 - TRK #62 - LOAD OF DIRT	1	400.00	400.00
	TKT #159715 - TRK #62 - LOAD OF DIRT	1	400.00	400.00
	TKT #159716 - TRK #62 - LOAD OF DIRT	1	400.00	400.00

PLEASE PAY UPON RECEIPT.
THANK YOU FOR YOUR BUSINESS!

SUBTOTAL 1,600.00
TAX 0.00
TOTAL 1,600.00

TOTAL DUE \$1,600.00

*Mr. Vijay
UDC*

RECEIVED
6/6/24

RODGERS BROTHERS SERVICE,
INC.
POST OFFICE BOX 41545
WASHINGTON, DC 20018
+13013227131

BILL TO
CONSYS, INC.
POST OFFICE BOX 60825
WASHINGTON, DC 20039

SHIP TO
ANTELOPE LANE
CAPITOL HEIGHTS, MD

INVOICE 39462

DATE 04/25/2024 TERMS Due on receipt

SHIP DATE
04/24/2024

SHIP VIA
4200 CONN. AVE., N.W. -W ASH DC

DATE	DESCRIPTION	QTY	RATE	AMOUNT
04/24/2024	TKT #159297 - TRK #65 - LOAD OF DIRT	1	400.00	400.00
	TKT #159298 - TRK #65 - LOAD OF DIRT	1	400.00	400.00
	TKT #159299 - TRK #65 - LOAD OF DIRT	1	400.00	400.00
	TKT #159300 - TRK #65 - LOAD OF DIRT	1	400.00	400.00
	TKT #159359 - TRK #64 - LOAD OF DIRT	1	400.00	400.00

PLEASE PAY UPON RECEIPT.
THANK YOU FOR YOUR BUSINESS!

SUBTOTAL 2,000.00
TAX 0.00
TOTAL 2,000.00
TOTAL DUE \$2,000.00

Mr. O'Jay
UDC

RECEIVED
6/6/24

RODGERS BROTHERS SERVICE,
INC.
POST OFFICE BOX 41545
WASHINGTON, DC 20018
+13013227131

BILL TO
CONSYS, INC.
POST OFFICE BOX 60825
WASHINGTON, DC 20039

SHIP TO
ANTELOPE LANE
CAPITOL HEIGHTS, MD

INVOICE 39501

DATE 05/20/2024 TERMS Due on receipt

SHIP DATE
05/13/2024

SHIP VIA
4200 CONN., AVE, NW - WASH., DC

DATE	DESCRIPTION	QTY	RATE	AMOUNT
05/13/2024	TKT #159748 - TRK #62 - LOAD OF DIRT	1	400.00	400.00
	TKT #159750 - TRK #62 - LOAD OF DIRT	1	400.00	400.00
	TKT #159752 - TRK #62 - LOAD OF DIRT	1	400.00	400.00
	TKT #159749 - TRK #64 - LOAD OF DIRT	1	400.00	400.00
	TKT #159751 - TRK #64 - LOAD OF DIRT	1	400.00	400.00
	TKT #159753 - TRK #64 - LOAD OF DIRT	1	400.00	400.00
	TKT #159114 - TRK #65 - LOAD OF DIRT	1	400.00	400.00
	TKT #159135 - TRK #65 - LOAD OF DIRT	1	400.00	400.00
	TKT #159136 - TRK #65 - LOAD OF DIRT	1	400.00	400.00
	TKT #159137 - TRK #65 - LOAD OF DIRT	1	400.00	400.00

PLEASE PAY UPON RECEIPT.
THANK YOU FOR YOUR BUSINESS!

SUBTOTAL 4,000.00
TAX 0.00
TOTAL 4,000.00

TOTAL DUE \$4,000.00

Mr. Vijay
UDC



RECEIVED

6/6/24

RODGERS BROTHERS SERVICE,
INC.
POST OFFICE BOX 41545
WASHINGTON, DC 20018
+13013227131

BILL TO
CONSYS, INC.
POST OFFICE BOX 60825
WASHINGTON, DC 20039

SHIP TO
ANTELOPE LANE
CAPITOL HEIGHTS, MD

INVOICE 39502

DATE 05/16/2024 TERMS Due on receipt

SHIP DATE
05/15/2024

SHIP VIA
4200 CONN AVE., NW - WASH., DC

DATE	DESCRIPTION	QTY	RATE	AMOUNT
05/14/2024	TKT #159995 - TRK #61 - LOAD OF DIRT	1	400.00	400.00
	TKT #159755 - TRK #62 - LOAD OF DIRT	1	400.00	400.00
	TKT #159756 - TRK #62 - LOAD OF DIRT	1	400.00	400.00
	TKT #159990 - TRK #62 - LOAD OF DIRT	1	400.00	400.00
	TKT #159758 - TRK #64 - LOAD OF DIRT	1	400.00	400.00
	TKT #159759 - TRK #64 - LOAD OF DIRT	1	400.00	400.00
	TKT #159994 - TRK #64 - LOAD OF DIRT	1	400.00	400.00
	TKT #159115 - TRK #65 - LOAD OF DIRT	1	400.00	400.00
	TKT #159133 - TRK #65 - LOAD OF DIRT	1	400.00	400.00
	TKT #159134 - TRK #65 - LOAD OF DIRT	1	400.00	400.00
	TKT #159362 - TRK #65 - LOAD OF DIRT	1	400.00	400.00

PLEASE PAY UPON RECEIPT.
THANK YOU FOR YOUR BUSINESS!

SUBTOTAL 4,400.00
TAX 0.00
TOTAL 4,400.00

TOTAL DUE \$4,400.00

*Mr. Vijay
UDC*



RECEIVED

6/6/24

RODGERS BROTHERS SERVICE,
INC.
POST OFFICE BOX 41545
WASHINGTON, DC 20018
+13013227131

BILL TO
CONSYS, INC.
POST OFFICE BOX 60825
WASHINGTON, DC 20039

SHIP TO
ANTELOPE LANE
CAPITOL HEIGHTS, MD

INVOICE 39503

DATE 05/17/2024 TERMS Due on receipt

SHIP DATE
05/16/2024

SHIP VIA
4200 CONN. AVE., NW - WASH., DC

DATE	DESCRIPTION	QTY	RATE	AMOUNT
05/16/2024	TKT #159898 - TRK #61 - LOAD OF DIRT	1	400.00	400.00
	TKT #159899 - TRK #61 - LOAD OF DIRT	1	400.00	400.00
	TKT #159900 - TRK #61 - LOAD OF DIRT	1	400.00	400.00
	TKT #159734 - TRK #62 - LOAD OF DIRT	1	400.00	400.00
	TKT #159735 - TRK #62 - LOAD OF DIRT	1	400.00	400.00
	TKT #159736 - TRK #62 - LOAD OF DIRT	1	400.00	400.00
	TKT #159737 - TRK #62 - LOAD OF DIRT	1	400.00	400.00
	TKT #158087 - TRK #63 - LOAD OF DIRT	1	400.00	400.00
	TKT #159365 - TRK #64 - LOAD OF DIRT	1	400.00	400.00
	TKT #159366 - TRK #64 - LOAD OF DIRT	1	400.00	400.00
	TKT #159397 - TRK #64 - LOAD OF DIRT	1	400.00	400.00
	TKT #159398 - TRK #64 - LOAD OF DIRT	1	400.00	400.00
	TKT #159116 - TRK #65 - LOAD OF DIRT	1	400.00	400.00
	TKT #159125 - TRK #65 - LOAD OF DIRT	1	400.00	400.00
	TKT #159143 - TRK #65 - LOAD OF DIRT	1	400.00	400.00

PLEASE PAY UPON RECEIPT.
THANK YOU FOR YOUR BUSINESS!

SUBTOTAL 6,000.00
TAX 0.00
TOTAL 6,000.00

TOTAL DUE \$6,000.00

Mr. Vijay
WCD



RECEIVED
6/6/24

RODGERS BROTHERS SERVICE,
INC.
POST OFFICE BOX 41545
WASHINGTON, DC 20018
+13013227131

BILL TO
CONSYS, INC.
POST OFFICE BOX 60825
WASHINGTON, DC 20039

SHIP TO
ANTELOPE LANE
CAPITOL HEIGHTS, MD

INVOICE 39504

DATE 05/20/2024 TERMS Due on receipt

SHIP DATE
05/17/2024

SHIP VIA
4200 CONN. AVE., N.W. - WASH.DC

DATE	DESCRIPTION	QTY	RATE	AMOUNT
05/17/2024	TKT #159745 - TRK #62 - LOAD OF DIRT	1	400.00	400.00
	TKT #159743 - TRK #62 - LOAD OF DIRT	1	400.00	400.00
	TKT #159744 - TRK #62 - LOAD OF DIRT	1	400.00	400.00
	TKT #159746 - TRK #62 - LOAD OF DIRT	1	400.00	400.00
	TKT #158002 - TRK #64 - LOAD OF DIRT	1	400.00	400.00
	TKT #158003 - TRK #64 - LOAD OF DIRT	1	400.00	400.00
	TKT #158004 - TRK #64 - LOAD OF DIRT	1	400.00	400.00
	TKT #158005 - TRK #64 - LOAD OF DIRT	1	400.00	400.00
	TKT #158006 - TRK #64 - LOAD OF DIRT	1	400.00	400.00

PLEASE PAY UPON RECEIPT.
THANK YOU FOR YOUR BUSINESS!

SUBTOTAL 3,600.00
TAX 0.00
TOTAL 3,600.00

TOTAL DUE \$3,600.00

Mr Vijay
UDC

RECEIVED
6/6/24



CONTRACT NO.: GF-2020-C-0036

PROJECT NAME: UDC – Replace Natural Grass Athletic Field with Synthetic Turf

ATTACHMENT A - BCD 1 Back-up – Item No. 6

2502 Martin Luther King Junior Avenue, SE Washington, DC 20020
Office: (202) 545-1333; Fax: (202) 545-1339; e-mail: consys@consys-inc.net
www.consys-inc.net



December 18, 2023

VIA e-mail: eddie.whitaker@udc.edu
mgadson@udc.edu

Mr. Eddie Whitaker
Contracting Officer
The University of the District of Columbia
Office of Strategic Sourcing & Procurement
4200 Connecticut Avenue, NW
Building 39, Suite 200C
Washington, DC 20008

Re: Contract No. GF-2020-C-0036 – Replace Natural Grass Athletic Field with Synthetic Turf – PCR 22
Drinking Water line

Mr. Whitaker:

Consys, Inc. hereby submits this PCR for having to complete the below mentioned work for a firm lump sum price of **\$71,939.11.**

SCOPE OF WORK:

- Furnish and install new drinking water fountain in accordance with the ASI 2.4 issued by the A/E
- Domestic water line and yard hydrant
- Final clean-up of our area of work

We respectfully request you to review this PCR and issue us a necessary change order for this added work that has to be performed.

EXCLUSIONS:

- All permits and any utility deposit
- All mechanical, electrical, plumbing, sprinkler, architectural, FFE, access control and voice & data work
- All hazmat work

We, thank you once again for providing us the opportunity to submit this proposal. Our proposal is valid for a period of 30 days.

Consys, Inc. is a CBE & MDOT-MBE certified company.

If you need any further clarification, feel free to contact the undersigned at (202) 439-4123.

Sincerely,

Vijay R. Kasimsetty
Vice President

Cc: Joanna Edwards, Alan Walsh, COTR and File

732 Kennedy Street, NW Washington, DC 20011
Office: (202) 545-1333; Fax: (202) 545-1339; e-mail: consys@consys-inc.net
www.consys-inc.net



Construction Estimate

Project: GF-2020-C-0036, RNgAFwST - PCR - 22 Drinking Water Line

Item No.	Description	Unit	Quantity	Material	Material Costs	Labor Rate	Hours	Labor Costs	Equipment	Line Total	Subcontractor	Remarks
1	Excavation & Backfill for New Water line	Job	1		\$ -	\$ 95.00	80	\$ 7,600.00	\$ 3,500.00	\$ 11,100.00		
2	Sand bedding for New Water line	Job	1	\$ 3,500.00	\$ 3,500.00	\$ 95.00	40	\$ 3,800.00		\$ 7,300.00		
3	New Drinking Water line, Bottle Station & Floor Drain	Job	1		\$ -			\$ -		\$ -	\$32,795.00	See attached quote
4	Haul Spoils	CY	42	\$ 50.00	\$ 2,100.00			\$ -	\$ 2,500.00	\$ 4,600.00		
5	Survey and Layout	Job	1		\$ -			\$ -		\$ -	\$1,500.00	1 additional trip @ \$1,500.00
6					\$ -			\$ -		\$ -		
7					\$ -			\$ -		\$ -		
8					\$ -			\$ -		\$ -		
9					\$ -			\$ -		\$ -		
10	Submittals & Shopdrawings	Job	1		\$ -	\$ 135.00	30	\$ 4,050.00		\$ 4,050.00		
11	Senior Project Manager	Hrs			\$ -			\$ -		\$ -		
12	Project Manager	Hrs			\$ -			\$ -		\$ -		
13	Project Superintendent	Hrs			\$ -			\$ -		\$ -		
14	Project Engineer	Hrs			\$ -			\$ -		\$ -		
15	Skilled Laborer	Hrs			\$ -			\$ -		\$ -		
16	Unskilled Laborer	Hrs			\$ -			\$ -		\$ -		
17	Dumpster / Trash Disposal	Job			\$ -			\$ -		\$ -		
18	Final clean-up	Job			\$ -			\$ -		\$ -		
SUBTOTAL										\$ 27,050.00	\$ 34,295.00	
OH @ 10%										\$ 2,705.00	\$ -	
PROFIT @ 10%										\$ 2,705.00	\$ 3,429.50	
SUB TOTAL										\$ 32,460.00	\$ 37,724.50	
BOND & INSURANCE COST										\$ 811.50	\$ 943.11	
TOTAL										\$ 33,271.50	\$ 38,667.61	
GRAND TOTAL										\$	71,939.11	

1. The above proposal is valid as a lump sum and breakdown of individual task is for informational purposes only.

2. Equipment includes dump truck, dump fees, hauling costs, power tools such as saws, air compressors, safety equipment, hand tools, wheel barrows etc. (as applicable to the job).

3. Labor rates include labor burden including Worker's Comp. Ins., Other Ins., FICA, Unemployment etc.

4. EXCLUSIONS: SEE COVER LETTER

5. PRICE QUALIFICATION : Because of current supply chain challenges, most construction products are subject to delayed delivery times and unusual price volatility due to conditions that are beyond of the General Contractor. Currently, we are unable to procure any future price obligations from the various subcontractors and manufacturers. As a result, we are unable to offer any price protection for this job. The pricing presented are based upon current material costs, which are subject to change at any time. CONSYS, Inc is doing their best to mitigate these issues, but we can't be held responsible for the cost or material delivery impacts that are beyond our control. If there is an increase in the cost of the products between when the project is bid and when the work is performed, the amount of the contract may increase to reflect the additional costs being incurred. If product delivery issues or material increases occur, we will provide proper notification and documentation to support any claims submitted.



5606 Tuxedo Rd. Hyattsville, MD 20781

240-3671109

1/23/2024

Consys , Inc.
2502 Martin Luther King Av SE
Washington, DC 20020

Attn: Vijay

Re: UDC Field

Proposal /Scope work

Includes:

1. Supply and install a Bottle filler and hose bit hydrant
2. Run 1' copper pipe about 120 feet from the building to out side supply drinking fountain
3. Run 297 feet ¾ copper pipe to supply hose bit
4. provide and install 4" floor drain new concrete stairs

Excludes:

1. Exterior work. Demo existing piping and plumbing fixtures
2. Anything not stated above.

Proposed Price for the Above-----\$32,795.00

*Due to the varied methods of pipe sizing, we size and bid per local code.

Ivotech Mechanical Services policy is not to do any change order work without approved and signed Change order by authorized personnel of Consys Construction, Inc.

Respectfully,
IvanC

IC/



CONTRACT NO.: GF-2020-C-0036

PROJECT NAME: UDC – Replace Natural Grass Athletic Field with Synthetic Turf

ATTACHMENT A - BCD 1 Back-up – Item No. 7

2502 Martin Luther King Junior Avenue, SE Washington, DC 20020
Office: (202) 545-1333; Fax: (202) 545-1339; e-mail: consys@consys-inc.net
www.consys-inc.net



May 20, 2024

VIA e-mail: eddie.whitaker@udc.edu
mgadson@udc.edu

Mr. Eddie Whitaker
Contracting Officer
The University of the District of Columbia
Office of Strategic Sourcing & Procurement
4200 Connecticut Avenue, NW
Building 39, Suite 200C
Washington, DC 20008

Re: Contract No. GF-2020-C-0036 – Replace Natural Grass Athletic Field with Synthetic Turf – PCR 23 - F & Install Topsoil and Sodding Athletic Field (DOEE)

Mr. Whitaker:

Consys, Inc. hereby submits this PCR for having to complete the below mentioned work for a firm lump sum price of **\$25,256.00**

SCOPE OF WORK:

- F & Install topsoil and sodding due to DOEE enforcement (See attached marked up drawing)
- Final clean-up of our area of work

We respectfully request you to review this PCR and issue us a necessary change order for this added work that has to be performed.

EXCLUSIONS:

- All permits and any utility deposit
- Excludes patching and repair of color concrete
- All structural support, roofing, architectural, mechanical, plumbing, sprinkler and FFE work
- All hazmat work

We, thank you once again for providing us the opportunity to submit this proposal. Our proposal is valid for a period of 30 days.

Consys, Inc. is a CBE & MDOT-MBE certified company.

If you need any further clarification, feel free to contact the undersigned at (202) 439-4123.

Sincerely,

Vijay Kasimsetty

Vijay R. Kasimsetty
Vice President

Cc: Alan Walsh, COTR and File

2502 Martin Luther King Junior Ave. SE Washington, DC 20020
Office: (202) 545-1333; Fax: (202) 545-1339; e-mail: consys@consys-inc.net
www.consys-inc.net



Construction Estimate

Project: GF-2020-C-0036, RNgAFwST - PCR 23 - F & Install Top Soil and Sodding Athletic Field (DOEE)

Item No.	Description	Unit	Quantity	Material	Material Costs	Labor Rate	Hours	Labor Costs	Equipment	Line Total	Subcontractor	Remarks
1	F & I top soil and sodding (DOEE)	Job	1		\$ -			\$ -		\$ -	\$22,400.00	See attached proposal
2					\$ -			\$ -		\$ -		
3					\$ -			\$ -		\$ -		
4					\$ -			\$ -		\$ -		
5					\$ -			\$ -		\$ -		
6					\$ -			\$ -		\$ -		
7					\$ -			\$ -		\$ -		
8					\$ -			\$ -		\$ -		
9					\$ -			\$ -		\$ -		
10					\$ -			\$ -		\$ -		
SUBTOTAL										\$ -	\$ 22,400.00	
OH @ 10%										\$ -	\$ -	
PROFIT @ 10%										\$ -	\$ 2,240.00	
SUB TOTAL										\$ -	\$ 24,640.00	
BOND & INSURANCE COST										\$ -	\$ 616.00	
TOTAL										\$ -	\$ 25,256.00	
GRAND TOTAL										\$	25,256.00	

1. The above proposal is valid as a lump sum and breakdown of individual task is for informational purposes only.

2. Equipment includes dump truck, dump fees, hauling costs, power tools such as saws, air compressors, safety equipment, hand tools, wheel barrows etc. (as applicable to the job).

3. Labor rates include labor burden including Worker's Comp. Ins., Other Ins., FICA, Unemployment etc.

4. EXCLUSIONS: SEE COVER LETTER

5. PRICE QUALIFICATION : Because of current supply chain challenges, most construction products are subject to delayed delivery times and unusual price volatility due to conditions that are beyond of the General Contractor. Currently, we are unable to procure any future price obligations from the various subcontractors and manufacturers. As a result, we are unable to offer any price protection for this job. The pricing presented are based upon current material costs, which are subject to change at any time. CONSYS, Inc is doing their best to mitigate these issues, but we can't be held responsible for the cost or material delivery impacts that are beyond our control. If there is an increase in the cost of the products between when the project is bid and when the work is performed, the amount of the contract may increase to reflect the additional costs being incurred. If product delivery issues or material increases occur, we will provide proper notification and documentation to support any claims submitted.

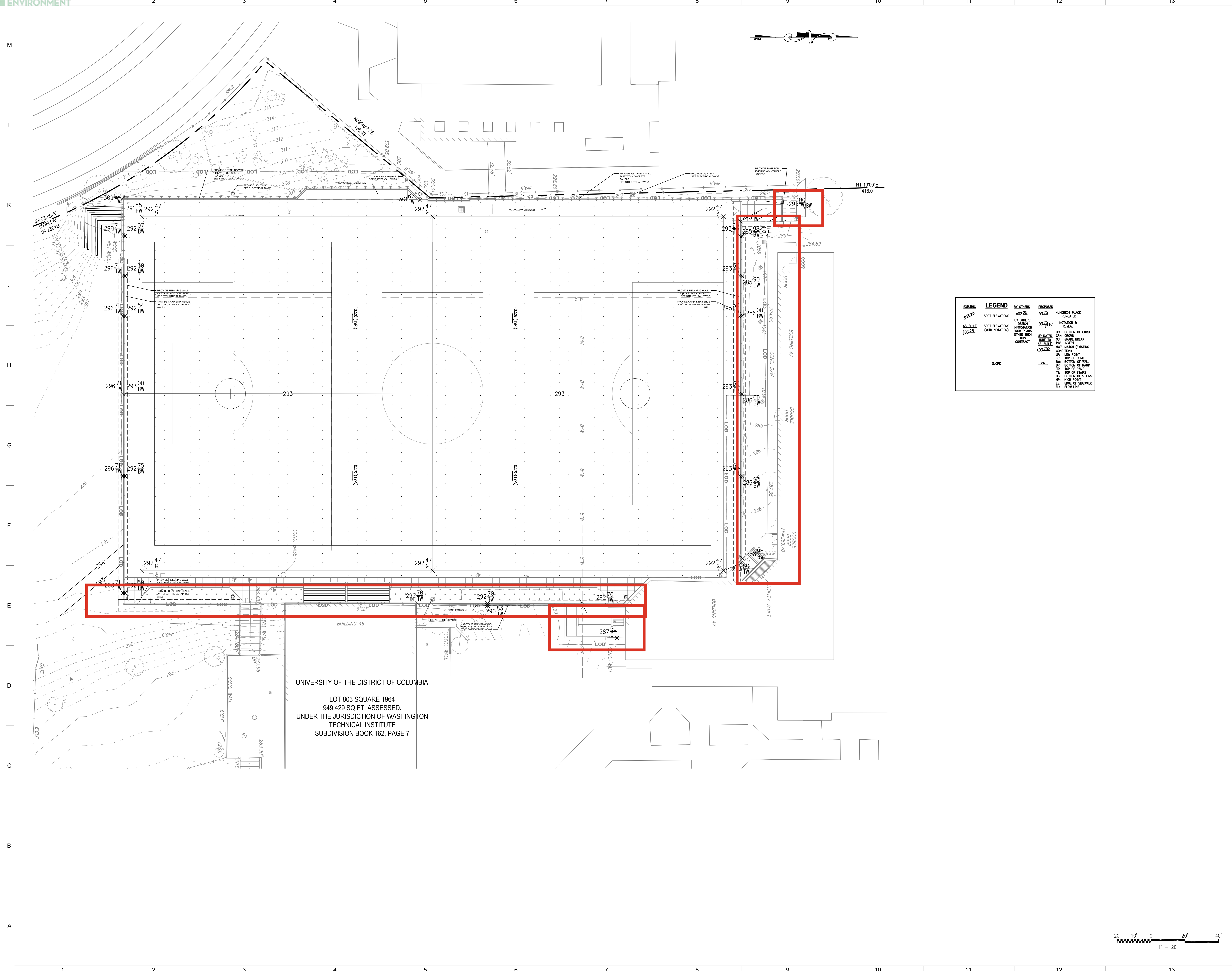

UNIVERSITY OF THE DISTRICT OF COLUMBIA
 LOT 803 SQUARE 1964
 949,429 SQ.FT. ASSESSED.
 UNDER THE JURISDICTION OF WASHINGTON
 TECHNICAL INSTITUTE
 SUBDIVISION BOOK 162, PAGE 7

EXISTING	LEGEND	BY OTHERS	PROPOSED
303.25	SPOT ELEVATIONS	403.25	03.25
AS-BUILD (63.25)	SPOT ELEVATIONS WITH NOTATION	BY OTHERS: REVISION INFORMATION FROM PLANS OTHER THAN THIS CONTRACT	03.45 TO
			BC: BOTTOM OF CURB CR: CROWN CB: CROWN BREAK IN: INVERT M: MATCH (EXISTING CONDITION) LP: LOW POINT TC: TOP OF CURB BW: BOTTOM OF WALL BR: BOTTOM OF RAMP TR: TOP OF RAMP TS: TOP OF STAIRS BS: BOTTOM OF STAIRS HP: HIGH POINT ES: EDGE OF SIDEWALK FL: FLOW LINE
	SLOPE		2%



2121 WARD PLACE, NW
 4TH FLOOR
 WASHINGTON, DC 20037
 v 202 298 6700
 f 202 298 6866
 WWW.QUINNEVANS.COM



UDC VAN NESS ATHLETIC FIELDS-NORTH

4200 CONNECTICUT AVE NW
 BUILDING 38, SUITE C01
 WASHINGTON, DC 20008
 QEA # 31607200
 OWNER # GF-2013-C-0114-C04-T0002

Grading Plan

ISSUED FOR PERMIT		
8/14/2020		
REVISIONS		
NO.	DESCRIPTION	DATE

CIV0106



E & F Landscaping, LLC

Woman Owned

12406 Crestwood Avenue South
Brandywine, MD 20613
(301) 782-1922 (301) 782-1923 Fax
Estimating@eandflandscape.com

DBE & SBE #11-047
D.C DBE #0004002
MDOT MBE #11-047
PG CBSB #15-333
VDOT #E982

ATTN: Vijay
Phone: 202-439-4123 email: vijay@consys-inc.net
RE: UDC Topsoil & Sod around perimeter of field

Estimate Created: Chris Carr
Bid Due Date: 5/15/2024

Our proposal is based on specific species, items, quantities, and landscape materials provided on

We propose to furnish and install the following:

Item	Code	Plant Species/Common Name/Size	Qty	Unit Cost	Total Cost
1		Delivery & Spread 4" depth topsoil ~110cy	110	\$140.00	\$15,400.00
2		Furnish & Install Sod sy	1000	\$7.00	\$7,000.00
3					\$0.00
4		Initial watering included			\$0.00
5					\$0.00
Total Proposed Cost					\$22,400.00

Unit Price		
Additional water per trip		\$1,250.00

Additional Pricing Available Upon Request
Additional Watering Charges Between the Period of May 15 – August 15 @ \$1250.00 per unit
For Additional Information Contact Chris Carr at 240-261-1263 or Estimating@eandflandscape.com

Specifically Excluded Are:

- * additional amendments to turf and planting area
- * spreading/ importing topsoil
- * preparation on subgrade/ rock removal
- * erosion/ stabilization controls
- * removal of spoils or debris
- * soil tests
- * bonds/ license / fees
- * drainage
- * soil/ backfill
- * irrigation

- * maintenance until completion of work only
- * watering other than initial
- * watering other than initial
- * maintenance/ watering
- * bio media / underdrains/ piping/excavating/ trenching for bio facilities
- * wage scale
- * tree wrap
- * transplanting
- * tree protection

Landscape Clarifications:

- E & F Landscaping does not guarantee germination of seeded areas if work is performed outside the recognized season, March 1st to May 15th and August 15th to October 15th. A **20%** increase will be added for seeding/sodding out of season.
- Seed/Sod pricing includes soil amendments such as lime and fertilizer, fine grading, and labor.
- Prices are based on items and quantities on the submitted specs and may not be modified
- All material is guaranteed as specified. Any alteration or deviation involving extra costs, will be executed only upon written orders. Additional charges will also incur if, during the course of normal construction, we encounter rocks or rock like conditions.
- We reserve the right to cease and/or postpone work due to adverse weather conditions. This proposal is further contingent upon the inclusion of the following escalation clause in the written subcontract between the parties: "Notwithstanding any provision of the subcontract to the contrary, if, after execution of the subcontract, the price of materials significantly increases, through no fault of E&F Landscaping, E&F Landscaping shall be entitled to an equitable adjustment of the costs of such materials. For purposes of this clause, 'significantly increases' means an increase of 10% or more. The equitable adjustment is calculated by the price actually paid by E&F Landscaping less the price planned at the time of the execution of the subcontract."

- All plant material is conditionally warranted for one (1) year/s. Plant warranty covers one (1) replacement event within the one-year warranty period. E&F Landscaping, LLC is not responsible for acts of God, neglect, wildlife predation and or/vandalism. Warranty becomes null and void when negligence due to insufficient watering is evident. Plant warranty does not include maintenance (pruning, cultivating, regular watering, and weeding, fertilizing, tightening, and repairing stakes) unless it is specifically priced as a line item.

- Due to the current volatility of the market as well as labor and supply chain issues, the pricing set forth in this proposal is valid for ten (10) days. If the parties have not fully executed a subcontract within ten (10) days, E&F Landscaping reserves the right to modify the pricing or other terms of this proposal. This proposal should not be relied upon for any period of time outside of the ten (10) day window without written confirmation from E&F Landscaping that the original proposal remains valid.
- Terms of Payment: Payment due within 30 days from date of invoice.

Respectfully Submitted,

Chris Carr

Acceptance of Proposal:

The prices, specifications and conditions are satisfactory and are hereby accepted. You are authorized to perform the work as specified. Payments will be made as outlined.

Signature: _____

Date: _____



CONTRACT NO.: GF-2020-C-0036

PROJECT NAME: UDC – Replace Natural Grass Athletic Field with Synthetic Turf

ATTACHMENT A - BCD 1 Back-up – Item No. 8

2502 Martin Luther King Junior Avenue, SE Washington, DC 20020
Office: (202) 545-1333; Fax: (202) 545-1339; e-mail: consys@consys-inc.net
www.consys-inc.net



July 30, 2024

VIA e-mail: eddie.whitaker@udc.edu
mgadson@udc.edu

Mr. Eddie Whitaker
Contracting Officer
The University of the District of Columbia
Office of Strategic Sourcing & Procurement
4200 Connecticut Avenue, NW
Building 39, Suite 200C
Washington, DC 20008

Re: Contract No. GF-2020-C-0036 – Replace Natural Grass Athletic Field with Synthetic Turf – PCR 25 -
New Emergency Vehicle Access Ramp at Southeast Location

Mr. Whitaker:

Consys, Inc. hereby submits this PCR for having to complete the below mentioned work for a firm lump sum price of **\$129,245.33.**

SCOPE OF WORK:

- Remove and re-grade gravel entrance
- Furnish and install additional drain tile work along new retaining wall
- Furnish and install all new site concrete work
- Furnish and install additional chain link fence
- Final clean-up of our area of work

We will need a 45-day time extension for this added work that is being performed.

EXCLUSIONS:

- All permits and any utility deposit
- Excludes patching and repair of color concrete
- All structural support, roofing, architectural, mechanical, plumbing, sprinkler, architectural and FFE work
- All hazmat work

We, thank you once again for providing us the opportunity to submit this proposal. Our proposal is valid for a period of 30 days.

Consys, Inc. is a CBE & MDOT-MBE certified company.

If you need any further clarification, feel free to contact the undersigned at (202) 439-4123.

Sincerely,

Vijay Kasimsetty

Vijay R. Kasimsetty
Vice President

Cc: Alan Walsh, COTR and File

2502 Martin Luther King Junior Ave. SE Washington, DC 20020
Office: (202) 545-1333; Fax: (202) 545-1339; e-mail: consys@consys-inc.net
www.consys-inc.net



Construction Estimate

Project: GF-2020-C-0036, RNGAFwST - PCR 25 - New Emergency Vehicle Access Ramp at Southeast Location)

Item No.	Description	Unit	Quantity	Material	Material Costs	Labor Rate	Hours	Labor Costs	Equipment	Line Total	Subcontractor	Remarks
1	Remove & rework construction entrance	Job	1		\$ -	\$ 95.00	40	\$ 3,800.00		\$ 3,800.00		In-house
2	Concrete work	Job	1		\$ -			\$ -		\$ -	\$71,970.00	See attached vendor quote
3	Surveyor	Job	1		\$ -			\$ -		\$ -	\$4,500.00	three trips at \$1,500.00 per trip
4	Additional Site Grading	Job	1		\$ -	\$ 95.00	80	\$ 7,600.00	\$ 2,500.00	\$ 10,100.00		In-house
5	Haul Spoils	CY	25	\$ 105.00	\$ 2,625.00			\$ -	\$ 2,500.00	\$ 5,125.00		In-house
6	Furnish and install additional Chain Link Fence	Job	1	\$ 3,100.00	\$ 3,100.00	\$ 65.00	32	\$ 2,080.00		\$ 5,180.00		In-house
7	Additioal drain tile work along new retaining wall	Job	1	\$ 1,195.00	\$ 1,195.00	\$ 95.00	24	\$ 2,280.00		\$ 3,475.00		In-house
8					\$ -			\$ -		\$ -		
9					\$ -			\$ -		\$ -		
10					\$ -			\$ -		\$ -		
11					\$ -			\$ -		\$ -		
12					\$ -			\$ -		\$ -		
13					\$ -			\$ -		\$ -		
14	Submittals	Job			\$ -	\$ 135.00	40	\$ 5,400.00		\$ 5,400.00		
15	Disposal of all trash	Job			\$ -			\$ -		\$ -		
16	Site clean-up	Job			\$ -			\$ -		\$ -		
17	Senior Project Manager	Hrs			\$ -			\$ -		\$ -		
18	Project Manager	Hrs			\$ -			\$ -		\$ -		
19	Project Superintendent	Hrs			\$ -			\$ -		\$ -		
20	Skilled Laborer	Hrs			\$ -			\$ -		\$ -		
21	Dumpster	Job			\$ -			\$ -	\$ 1,900.00	\$ 1,900.00		
22					\$ -			\$ -		\$ -		
SUBTOTAL										\$ 34,980.00	\$ 76,470.00	
OH @ 10%										\$ 3,498.00	\$ -	
PROFIT @ 10%										\$ 3,498.00	\$ 7,647.00	
SUB TOTAL										\$ 41,976.00	\$ 84,117.00	
BOND & INSURANCE COST										\$ 1,049.40	\$ 2,102.93	
TOTAL										\$ 43,025.40	\$ 86,219.93	
GRAND TOTAL										\$	\$ 129,245.33	

1. The above proposal is valid as a lump sum and breakdown of individual task is for informational purposes only.

2. Equipment includes dump truck, dump fees, hauling costs, power tools such as saws, air compressors, safety equipment, hand tools, wheel barrows etc. (as applicable to the job).

3. Labor rates include labor burden including Worker's Comp. Ins, Other Ins., FICA, Unemployment etc.

4. EXCLUSIONS: SEE COVER LETTER

5. PRICE QUALIFICATION: Because of current supply chain challenges, most construction products are subject to delayed delivery times and unusual price volatility due to conditions that are beyond of the General Contractor. Currently, we are unable to procure any future price obligations from the various subcontractors and manufacturers. As a result, we are unable to offer any price protection for this job. The pricing presented are based upon current material costs, which are subject to change at any time. CONSYS, Inc is doing their best to mitigate these issues, but we can't be held responsible for the cost or material delivery impacts that are beyond our control. If there is an increase in the cost of the products between when the project is bid and when the work is performed, the amount of the contract may increase to reflect the additional costs being incurred. If product delivery issues or material increases occur, we will provide proper notification and documentation to support any claims submitted.

ADM Construction Inc.
Concrete
David P. Brady
7724 Delano Road Clinton, Maryland 20735
Office # (301) 856-7737 ❖ Fax # (301) 856-3965
Email: admconcrete.const@gmail.com

Date: July 26, 2024

Proposal Submitted: Consys, Inc.		Phone: (202) 545-1333
Street: 732 Kennedy Street NW		Fax:
City: Washington	State: DC	Zip: 20011
Job Name: UDC Athletic Field	Job Phone:	
Job Location: 4200 Connecticut Avenue NW – Washington, DC 20008		
Architect:	Date of Plan:	

We hereby propose to furnish material and labor to complete in accordance with specifications below for the sum of:

Attention: Vijay Kasimsetty (vijay@consys-inc.net)
Payment to be made as follows: Net 30 days; 2% interest charged on balance due over 30 days; 24% per annum

Change Order #9:

<p>Revised Grading Drawing: 7/18/24 <u>Foundation</u> 12" x 5' Retaining wall footing with #3 bars continuous at 12" OC #4 bars at 30" OC Transvers #4 dowels at 16" OC 8" Concrete Retaining wall, Height varies with a maximum height of 6' #4 bars at 16" OC EW 2" Weep holes at 8' OC Gravel fill at weep holes 2' x 1' with filter cloth Backfill and site excavated material behind wall Remove spoils not used for backfill or lost on site <u>Concrete pavement</u> Excavate 14" of existing subbase to install new concrete pavement Remove spoils from site Compact subbase 8" Concrete pavement with #5 bars 12" OC EW 6" Gravel base using RC-6 KS100 Trench drain estimated 10 LF Exclude plumbing tie in Price includes labor, materials, machine time, and dump fees</p>	\$ 71,970.00
---	--------------

ADM Concrete Construction
UDC Athletic Field – Washington DC
3/23/2025
Page 2

Signature of Acceptance Required _____

Date Signed _____



CONTRACT NO.: GF-2020-C-0036

PROJECT NAME: UDC – Replace Natural Grass Athletic Field with Synthetic Turf

ATTACHMENT A - BCD 1 Back-up – Item No. 9

2502 Martin Luther King Junior Avenue, SE Washington, DC 20020
Office: (202) 545-1333; Fax: (202) 545-1339; e-mail: consys@consys-inc.net
www.consys-inc.net



March 23, 2025

VIA e-mail: eddie.whitaker@udc.edu
mgadson@udc.edu

Mr. Eddie Whitaker
Contracting Officer
The University of the District of Columbia
Office of Strategic Sourcing & Procurement
4200 Connecticut Avenue, NW
Building 39, Suite 200C
Washington, DC 20008

Re: Contract No. GF-2020-C-0036 – Replace Natural Grass Athletic Field with Synthetic Turf – PCR 26 - Sand Bedding (RFI 33)

Mr. Whitaker:

Consys, Inc. hereby submits this PCR for having to complete the below mentioned work for a firm lump sum price of \$3,498.38.

SCOPE OF WORK:

- Furnish & Install necessary bedding as per RFI 33 response
- Final clean-up of our area of work

We respectfully request you to review this PCR and issue us a necessary change order for this added work that has to be performed.

EXCLUSIONS:

- All permits and any utility deposit
- All mechanical, electrical, plumbing, sprinkler, architectural, FFE, access control and voice & data work
- All hazmat work

We, thank you once again for providing us the opportunity to submit this proposal. Our proposal is valid for a period of 30 days.

Consys, Inc. is a CBE & MDOT-MBE certified company.

If you need any further clarification, feel free to contact the undersigned at (202) 439-4123.

Sincerely,

Vijay R. Kasimsetty
Vice President

Cc: Joanna Edwards, Alan Walsh, COTR and File

2502 Martin Luther King Junior Avenue, SE Washington, DC 20020
Office: (202) 545-1333; Fax: (202) 545-1339; e-mail: consys@consys-inc.net
www.consys-inc.net



Construction Estimate

Project: GF-2020-C-0036, RNgAFwST - PCR 26 - Sand Bedding (RFI 33)

Item No.	Description	In-House	Subcontractor	Remarks
1	F & Install sand bedding for existing utility lines	\$ 2,850.00		In-house
2				
3				
4				
5				
6				
7				
8				
9				
10				
11				
12				
13				
14				
15				
16				
17				
18				
19				
20				
21				
	Sub-Total	\$ 2,850.00	\$ -	
	OH	\$ 285.00	\$ -	
	Profit	\$ 285.00	\$ -	
	Bonds & Insurance	\$ 78.38	\$ -	
	TOTAL	\$ 3,498.38	\$ -	
	GRAND TOTAL	\$	3,498.38	

Note: 1. The above proposal is valid as a lump sum and breakdown of individual task is for informational purposes only.

2. Equipment includes dump truck, dump fees, hauling costs, power tools such as saws, air compressors, safety equipment, hand tools, wheel barrows etc. (as applicable to the job).

3. Labor rates include labor burden including Worker's Comp. Ins, Other Ins., FICA, Unemployment etc.

EXCLUSIONS: SEE COVER LETTER

PRICE QUALIFICATION : Because of current supply chain challenges, most construction products are subject to delayed delivery times and unusual price volatility due to conditions that are beyond of the General Contractor. Currently, we are unable to procure any future price obligations from the various subcontractors and manufacturers. As a result, we are unable to offer any price protection for this job. The pricing presented are based upon current material costs, which are subject to change at any time. CONSYS, Inc is doing their best to mitigate these issues, but we can't be held responsible for the cost or material delivery impacts that are beyond our control. If there is an increase in the cost of the products between when the project is bid and when the work is performed, the amount of the contract may increase to reflect the additional costs being incurred. If product delivery issues or material increases occur, we will provide proper notification and documentation to support any claims submitted.



CONTRACT NO.: GF-2020-C-0036

PROJECT NAME: UDC – Replace Natural Grass Athletic Field with Synthetic Turf

ATTACHMENT A -BCD 1 Back-up – ItemNo.10

2502 Martin Luther King Junior Avenue, SE Washington, DC 20020
Office: (202) 545-1333; Fax: (202) 545-1339; e-mail: consys@consys-inc.net
www.consys-inc.net



April 12, 2024

VIA e-mail: eddie.whitaker@udc.edu
mgadson@udc.edu

Mr. Eddie Whitaker
Contracting Officer
The University of the District of Columbia
Office of Strategic Sourcing & Procurement
4200 Connecticut Avenue, NW
Building 39, Suite 200C
Washington, DC 20008

Re: Contract No. GF-2020-C-0036 – Replace Natural Grass Athletic Field with Synthetic Turf – PCR 27 -
Additional Concrete Curb (RFI 31 Response)

Mr. Whitaker:

Consys, Inc. hereby submits this PCR for having to complete the below mentioned work for a firm lump sum price of **\$47,614.94**

SCOPE OF WORK:

- Furnish and install new concrete curb with footing and reinforcement as per response to RFI 31
- Final clean-up of our area of work

We respectfully request you to review this PCR and issue us a necessary change order for this added work that has to be performed.

EXCLUSIONS:

- All permits and any utility deposit
- All mechanical, electrical, plumbing, sprinkler, architectural, FFE, access control and voice & data work
- All hazmat work

We, thank you once again for providing us the opportunity to submit this proposal. Our proposal is valid for a period of 30 days.

Consys, Inc. is a CBE & MDOT-MBE certified company.

If you need any further clarification, feel free to contact the undersigned at (202) 439-4123.

Sincerely,

Vijay R. Kasimsetty
Vice President

Cc: Joanna Edwards, Alan Walsh, COTR and File

732 Kennedy Street, NW Washington, DC 20011
Office: (202) 545-1333; Fax: (202) 545-1339; e-mail: consys@consys-inc.net
www.consys-inc.net



Construction Estimate

Project: GF-2020-C-0036, RNGAFwST - PCR 27 - Additional Concrete Curb (RFI 31 Response)

Item No.	Description	Unit	Quantity	Material	Material Costs	Labor Rate	Hours	Labor Costs	Equipment	Line Total	Subcontractor	Remarks
1	F & I new concrete curb with footing and reinforcement	Job	1		\$ -			\$ -		\$ -	\$22,976.00	RFI 31 Response
2	Backfill	job	1		\$ -	\$ 65.00	80	\$ 5,200.00	\$ 1,200.00	\$ 6,400.00		
3	Haul Spoils off site	job	1		\$ -	\$ 65.00	80	\$ 5,200.00	\$ 3,600.00	\$ 8,800.00		4 trucks
4		Job	1		\$ -			\$ -		\$ -		
5		Job	1		\$ -			\$ -		\$ -		
6		Job			\$ -			\$ -		\$ -		
7		Job	1		\$ -			\$ -		\$ -		
8		Job	1		\$ -			\$ -		\$ -		
9					\$ -			\$ -		\$ -		
10	Project Coordination	Job			\$ -	\$ 175.00	14	\$ 2,450.00		\$ 2,450.00		
11	Disposal of all trash	Job			\$ -			\$ -		\$ -		
12	Site clean-up	Job			\$ -			\$ -		\$ -		
13	Senior Project Manager	Hrs			\$ -			\$ -		\$ -		
14	Project Manager	Hrs			\$ -			\$ -		\$ -		
15	Project Superintendent	Hrs			\$ -			\$ -		\$ -		
16	Skilled Laborer	Hrs			\$ -	\$ 55.00		\$ -		\$ -		
17	Dumpster	Job			\$ -			\$ -		\$ -		
SUBTOTAL										\$ 17,650.00	\$ 22,976.00	
OH @ 10%										\$ 1,765.00	\$ -	
PROFIT @ 10%										\$ 1,765.00	\$ 2,297.60	
SUB TOTAL										\$ 21,180.00	\$ 25,273.60	
BOND & INSURANCE COST										\$ 529.50	\$ 631.84	
TOTAL										\$ 21,709.50	\$ 25,905.44	
GRAND TOTAL										\$	47,614.94	

1. The above proposal is valid as a lump sum and breakdown of individual task is for informational purposes only.

2. Equipment includes dump truck, dump fees, hauling costs, power tools such as saws, air compressors, safety equipment, hand tools, wheel barrows etc. (as applicable to the job).

3. Labor rates include labor burden including Worker's Comp. Ins., Other Ins., FICA, Unemployment etc.

4. EXCLUSIONS: SEE COVER LETTER

5. PRICE QUALIFICATION: Because of current supply chain challenges, most construction products are subject to delayed delivery times and unusual price volatility due to conditions that are beyond of the General Contractor. Currently, we are unable to procure any future price obligations from the various subcontractors and manufacturers. As a result, we are unable to offer any price protection for this job. The pricing presented are based upon current material costs, which are subject to change at any time. CONSYS, Inc is doing their best to mitigate these issues, but we can't be held responsible for the cost or material delivery impacts that are beyond our control. If there is an increase in the cost of the products between when the project is bid and when the work is performed, the amount of the contract may increase to reflect the additional costs being incurred. If product delivery issues or material increases occur, we will provide proper notification and documentation to support any claims submitted.

ADM Construction Inc.
Concrete
David P. Brady
7724 Delano Road Clinton, Maryland 20735
Office # (301) 856-7737 ❖ Fax # (301) 856-3965
Email: admconcrete.const@gmail.com

Date: April 12, 2024

Proposal Submitted: Consys, Inc.		Phone: (202) 545-1333
Street: 732 Kennedy Street NW		Fax:
City: Washington	State: DC	Zip: 20011
Job Name: UDC Athletic Field	Job Phone:	
Job Location: 4200 Connecticut Avenue NW – Washington, DC 20008		
Architect:	Date of Plan:	

We hereby propose to furnish material and labor to complete in accordance with specifications below for the sum of:

Attention: Vijay Kasimsetty (vijay@consys-inc.net)
Payment to be made as follows: Net 30 days; 2% interest charged on balance due over 30 days; 24% per annum

Change Order #6:

RFI – 031 – Concrete knee wall ADM will install 8" knee wall located on the East side per RFI 031 Foundation 3' x 12" footing with #5 Bars at 12" OC EW T&B With #5 dowels at 12" OC 8" Concrete wall estimated 2'6" tall by 86' long with #5 bars 12" OC EW Price includes labor machine time and materials. Exclude backfill and removal of material .	\$ 22,976.00
---	---------------------

Signature of Acceptance Required _____ \

Date Signed _____



REQUEST FOR INFORMATION

To: Quinn Evans Architects RFI No: 031 Date: 03/06/2024

Attn: Christine Cho

Contract No.: GF-2020-C-0036

For: Information/Action

Title: Chain Link Fence on Top of Existing Retaining Wall at South East Elevation Clarification.

From: Vijay Kasimsetty

cc: Joanna Edwards, Alan Walsh, Lisa Sleith, Surinder Khanna, Ronald Alvarenga, and File

REPLY NEEDED BY: 03/08/2024.

QUESTIONS:

We are in the process of forming up the walls in the South East elevation of the new athletic field. The contract drawings show to install a new Chain Link Fence on top of the existing retaining wall, however, there was never an existing retaining wall in this location. Please clarify and advise. (see attachments).

Please review and respond as soon as possible. Additional cost may be associated with this RFI. If any additional clarification is needed, feel free to contact the undersigned at (202) 439-4123.

Vijay R. Kasimsetty

Vijay R. Kasimsetty
Vice President

Copy to: Job File

REPLY:

Date: _____

Name: _____

Title: _____

*Provide curb/wall to mount the fence on top per CIV106.
QE/WM 24 0403*

2502 Martin Luther King Jr. Avenue SE, Washington, DC 20011
Office: (202) 545-1333; Fax: (202) 545-1339; e-mail: consys@consys-inc.net
www.consys-inc.net

These plans are conditionally approved as submitted or noted during plan review and are subject to field inspection. Approved plans must be kept on site and are needed for all inspections. No changes or modifications to these plans. Changes require a revision permit with the revised plans. Trade Permits are required for trade work. e.g. Electrical or Plumbing

Electrical Review - Saima Dar - 10-06-2021
 Fire Review - Luchi Liu - 10-06-2021
 DCEE SE-SW Review - Nykia Barnes - 10-06-2021



2121 WARD PLACE, NW
 4TH FLOOR
 WASHINGTON, DC 20037
 v 202 298 6700
 f 202 298 6866
 WWW.QUINNEVANS.COM



UDC VAN NESS ATHLETIC FIELDS-NORTH

4200 CONNECTICUT AVE NW
 BUILDING 38, SUITE C01
 WASHINGTON, DC 20008
 QEA # 31607200
 OWNER # GF-2013-C-0114-C04-T0002

Grading Plan

ISSUED FOR PERMIT		
8/14/2020		
REVISIONS		
NO.	DESCRIPTION	DATE

CIV0106

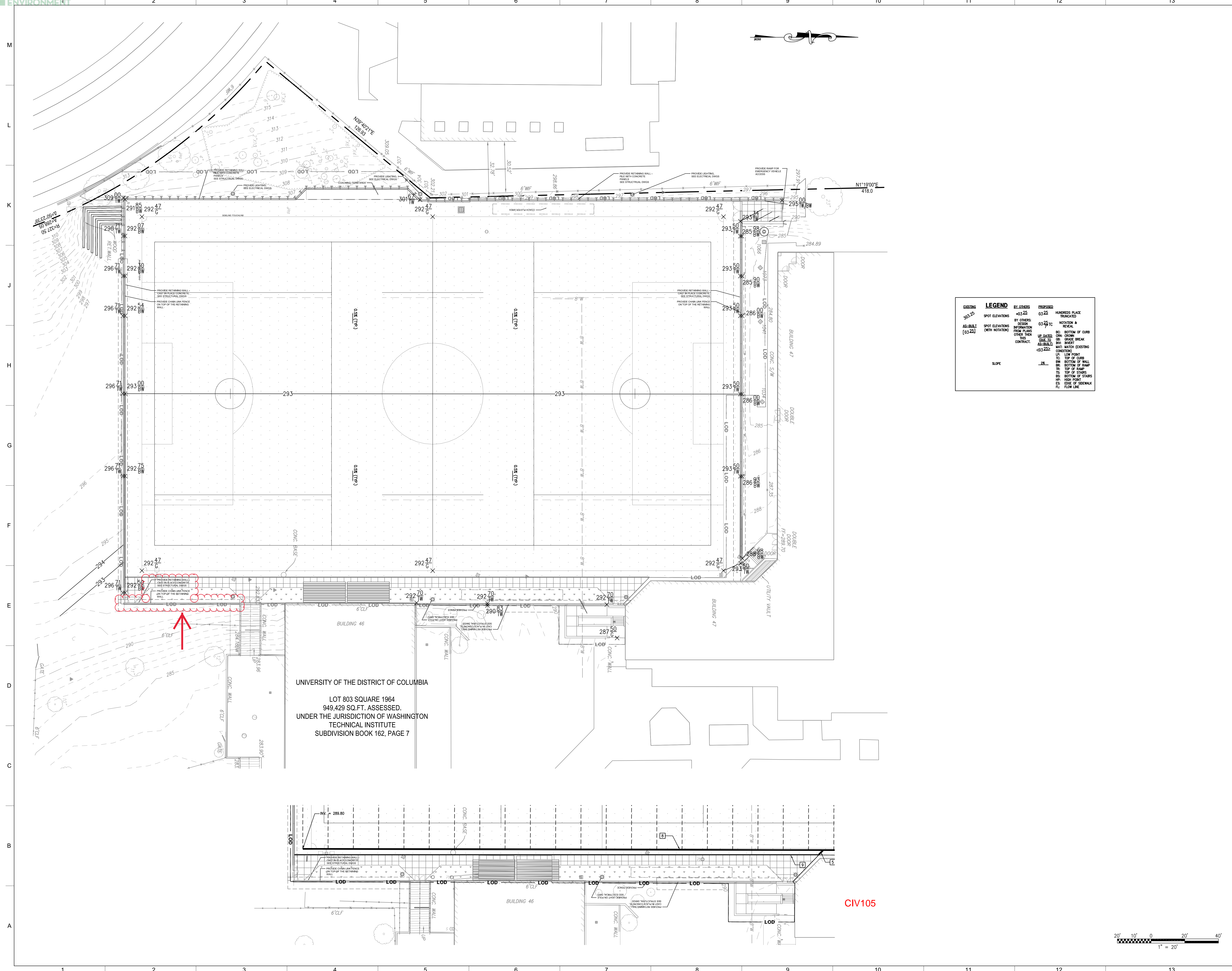

These plans are conditionally approved as submitted or noted during plan review and are subject to field inspection. Approved plans must be kept on site and are needed for all inspections. No changes or modifications to these plans. Changes require a revision permit with the revised plans. Trade Permits are required for trade work. e.g. Electrical or Plumbing

Electrical Review - Saima Dar - 10-06-2021
 Fire Review - Luchi Liu - 10-06-2021
 DCEE SE-SW Review - Nykia Barnes - 10-06-2021
 DCRA STAMP



2121 WARD PLACE, NW
 4TH FLOOR
 WASHINGTON, DC 20037
 v 202 298 6700
 f 202 298 6866
 WWW.QUINNEVANS.COM



**UDC VAN NESS
 ATHLETIC
 FIELDS-
 NORTH**

4200 CONNECTICUT AVE NW
 BUILDING 38, SUITE C01
 WASHINGTON, DC 20008
 QEA # 31607200
 OWNER #
 GF-2013-C-0114-C04-T0002

**SITE PLAN
 ELEVATION
 NEW WORK
 NE QDRT**

PERMIT SET 8/14/2020

REVISIONS		
NO.	DESCRIPTION	DATE

A100d

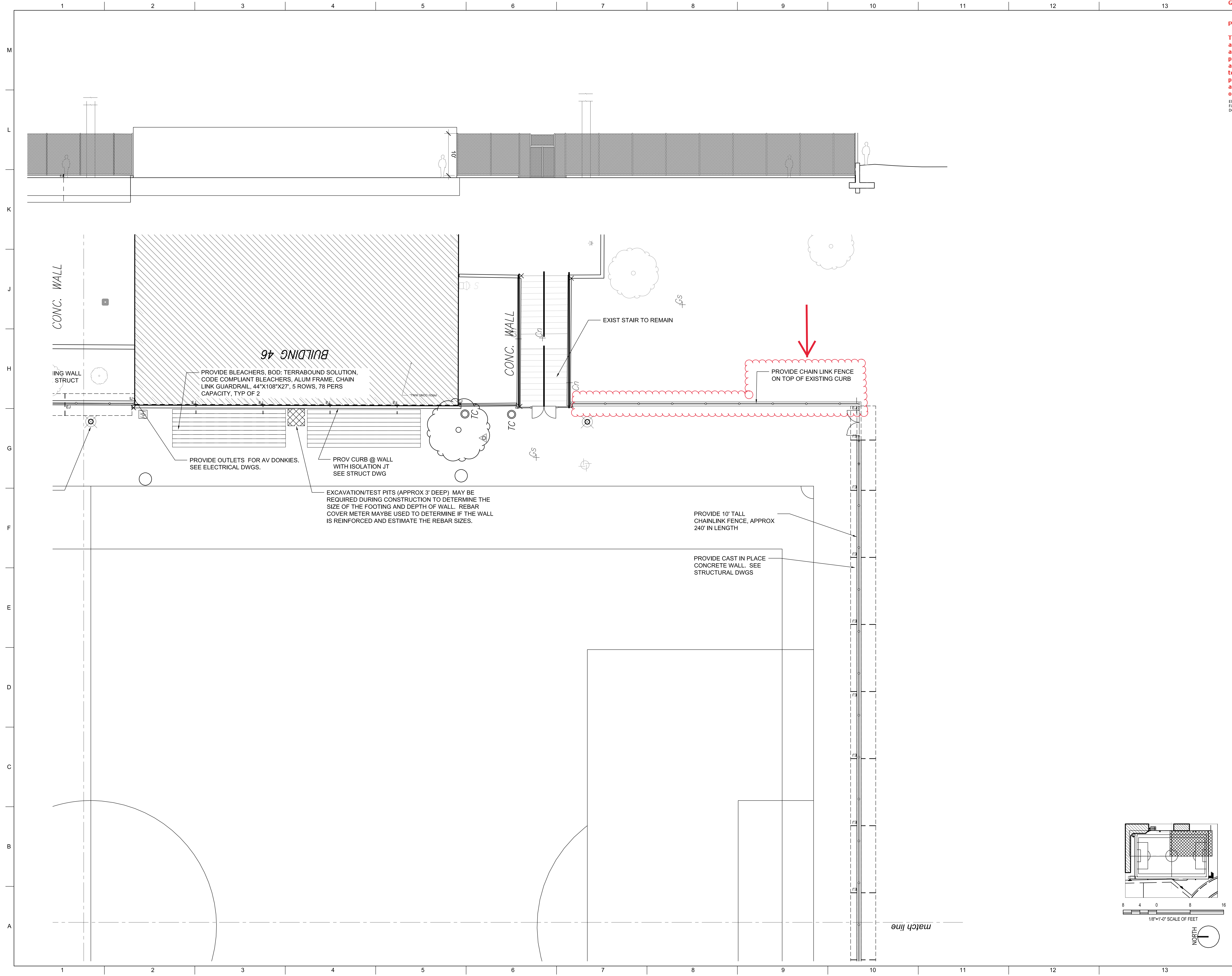



CONTRACT NO.: GF-2020-C-0036

PROJECT NAME: UDC – Replace Natural Grass Athletic Field with Synthetic Turf

ATTACHMENT A -BCD 1 Back-up – ItemNo.11

2502 Martin Luther King Junior Avenue, SE Washington, DC 20020
Office: (202) 545-1333; Fax: (202) 545-1339; e-mail: consys@consys-inc.net
www.consys-inc.net



August 08, 2023

VIA e-mail: eddie.whitaker@udc.edu
mgadson@udc.edu

Mr. Eddie Whitaker
Contracting Officer
The University of the District of Columbia
Office of Strategic Sourcing & Procurement
4200 Connecticut Avenue, NW
Building 39, Suite 200C
Washington, DC 20008

Re: Contract No. GF-2020-C-0036 – Replace Natural Grass Athletic Field with Synthetic Turf – PCR 28 -
Additional Work Unidentified Concrete Structures

Mr. Whitaker:

Consys, Inc. hereby submits this PCR for having to complete the below mentioned work for a firm lump sum price of \$31,162.50.

SCOPE OF WORK:

- Remove, handle and dispose unidentified buried concrete structures
- Final clean-up of our area of work

We respectfully request you to review this PCR and issue us a necessary change order for this added work that has to be performed.

EXCLUSIONS:

- All permits and any utility deposit
- All mechanical, electrical, plumbing, sprinkler, architectural, FFE, access control and voice & data work
- All hazmat work

We, thank you once again for providing us the opportunity to submit this proposal. Our proposal is valid for a period of 30 days.

Consys, Inc. is a CBE & MDOT-MBE certified company.

If you need any further clarification, feel free to contact the undersigned at (202) 439-4123.

Sincerely,

Vijay R. Kasimsetty
Vice President

Cc: Joanna Edwards, Alan Walsh, COTR and File

2502 Martin Luther King Junior Avenue, SE Washington, DC 20020
Office: (202) 545-1333; Fax: (202) 545-1339; e-mail: consys@consys-inc.net
www.consys-inc.net



Construction Estimate

Project: GF-2020-C-0036, RNGAFwST - PCR 28 - Additional Work Unidentified Concrete Structures

Item No.	Description	In-House	Subcontractor	Remarks
1	Process concrete debris		\$ 14,400.00	120 hrs @ \$120.00 per hour See unit rate proposal
2	Dumpster		\$ 6,300.00	10 dumpsters
3	Load Dumpster		\$ 2,000.00	10 dumpsters
4	Haul and dispose clean concrete		\$ 5,000.00	10 trucks
5				See unit rate proposal
6				
7				
8				
9				
10				
11				
12				
13				
14				
15				
16				
17				
18				
19				
20				
21				
	Sub-Total	\$ -	\$ 27,700.00	
	OH	\$ -	\$ -	
	Profit	\$ -	\$ 2,770.00	
	Bonds & Insurance	\$ -	\$ 692.50	
	TOTAL	\$ -	\$ 31,162.50	
	GRAND TOTAL	\$	31,162.50	

Note: 1. The above proposal is valid as a lump sum and breakdown of individual task is for informational purposes only.

2. Equipment includes dump truck, dump fees, hauling costs, power tools such as saws, air compressors, safety equipment, hand tools, wheel barrows etc. (as applicable to the job).

3. Labor rates include labor burden including Worker's Comp. Ins, Other Ins., FICA, Unemployment etc.

EXCLUSIONS: SEE COVER LETTER

PRICE QUALIFICATION : Because of current supply chain challenges, most construction products are subject to delayed delivery times and unusual price volatility due to conditions that are beyond of the General Contractor. Currently, we are unable to procure any future price obligations from the various subcontractors and manufacturers. As a result, we are unable to offer any price protection for this job. The pricing presented are based upon current material costs, which are subject to change at any time. CONSYS, Inc is doing their best to mitigate these issues, but we can't be held responsible for the cost or material delivery impacts that are beyond our control. If there is an increase in the cost of the products between when the project is bid and when the work is performed, the amount of the contract may increase to reflect the additional costs being incurred. If product delivery issues or material increases occur, we will provide proper notification and documentation to support any claims submitted.

PROPOSAL

RODGERS BROTHERS SERVICE
2230 Lawrence Ave, NE
Washington, DC 20018
(202)526-0274 • (240) 377-0566 FAX

PROPOSAL NO. 1

SHEET NO. _____

DATE June 15, 2023

PROPOSAL SUBMITTED TO:

Consys, Inc.
732 Kennedy Street, NW
Washington, DC 20011

WORK TO BE PERFORMED AT:

UDC-Athletic Field
Washington, DC 20018

We have visited the site and are familiar with the building. We hereby propose to furnish labor, materials, and equipment necessary to perform the following scope of work:

- | | |
|--|----------------------------------|
| 1. Haul & Disposal Clean Concrete (pieces less than 1 cubic foot): | \$500 |
| 2. Dumpster: | \$525 per load (3 ton allowance) |
| * | plus 20% fuel surcharge |
| 3. Load Debris into dumpster or truck: | \$200 per load |
| 4. Process concrete debris into 1 cubic foot size; | \$150 per hour |

Exclusions:

All material is guaranteed to be as specified, and the above work to be performed in accordance with the drawings and specifications submitted for the above work and completed in a substantial workmanlike manner for the sum stipulated above.

Respectfully submitted: _____

By: Sean K. Carney, Project Executive

Any alteration or deviation from above specifications involving extra costs will be executed only upon written order and will become an extra charge over and above the estimate. All agreements are contingent upon strikes, accidents or delays beyond our control.

ACCEPTANCE PROPOSAL

The above prices, specifications and conditions are satisfactory and are hereby accepted. You are authorized to do the work as specified. Payments will be made as outlined above.

Signature _____

Date _____



CONTRACT NO.: GF-2020-C-0036

PROJECT NAME: UDC – Replace Natural Grass Athletic Field with Synthetic Turf

ATTACHMENT A - BCD 1 Back-up – Item No. 12

2502 Martin Luther King Junior Avenue, SE Washington, DC 20020
Office: (202) 545-1333; Fax: (202) 545-1339; e-mail: consys@consys-inc.net
www.consys-inc.net



August 15, 2024

VIA e-mail: eddie.whitaker@udc.edu
mgadson@udc.edu

Mr. Eddie Whitaker
Contracting Officer
The University of the District of Columbia
Office of Strategic Sourcing & Procurement
4200 Connecticut Avenue, NW
Building 39, Suite 200C
Washington, DC 20008

Re: Contract No. GF-2020-C-0036 – Replace Natural Grass Athletic Field with Synthetic Turf – 29 - Chain Link Fence Fabric & Gauge (RFI 30)

Mr. Whitaker:

Consys, Inc. hereby submits this PCR for having to complete the below mentioned work for a firm lump sum price of **\$9,414.63**

SCOPE OF WORK:

- Change in fence fabric and gauge as per RFI 30 response
- Final clean-up of our area of work

We respectfully request you to review this PCR and issue us a necessary change order for this added work that has to be performed.

EXCLUSIONS:

- All permits and any utility deposit
- Excludes patching and repair of color concrete
- All structural support, roofing, architectural, mechanical, plumbing, sprinkler and FFE work
- All hazmat work

We, thank you once again for providing us the opportunity to submit this proposal. Our proposal is valid for a period of 30 days.

Consys, Inc. is a CBE & MDOT-MBE certified company.

If you need any further clarification, feel free to contact the undersigned at (202) 439-4123.

Sincerely,

Vijay R. Kasimsetty
Vice President

Cc: Alan Walsh, COTR and File

2502 Martin Luther King Junior Ave. SE Washington, DC 20020
Office: (202) 545-1333; Fax: (202) 545-1339; e-mail: consys@consys-inc.net
www.consys-inc.net



Construction Estimate

Project: GF-2020-C-0036, RNgAFwST - PCR 29 - Chain Linke Fence Fabric & Gauge (RFI 30)

Item No.	Description	Unit	Quantity	Material	Material Costs	Labor Rate	Hours	Labor Costs	Equipment	Line Total	Subcontractor	Remarks
1	Change in fence fabric & gauge	Job	1		\$ -			\$ -		\$ -	\$8,350.00	
2					\$ -			\$ -		\$ -		
3					\$ -			\$ -		\$ -		
4					\$ -			\$ -		\$ -		
5					\$ -			\$ -		\$ -		
6					\$ -			\$ -		\$ -		
7					\$ -			\$ -		\$ -		
8					\$ -			\$ -		\$ -		
9					\$ -			\$ -		\$ -		
10					\$ -			\$ -		\$ -		
SUBTOTAL										\$ -	\$ 8,350.00	
OH @ 10%										\$ -	\$ -	
PROFIT @ 10%										\$ -	\$ 835.00	
SUB TOTAL										\$ -	\$ 9,185.00	
BOND & INSURANCE COST										\$ -	\$ 229.63	
TOTAL										\$ -	\$ 9,414.63	
GRAND TOTAL										\$	9,414.63	

1. The above proposal is valid as a lump sum and breakdown of individual task is for informational purposes only.

2. Equipment includes dump truck, dump fees, hauling costs, power tools such as saws, air compressors, safety equipment, hand tools, wheel barrows etc. (as applicable to the job).

3. Labor rates include labor burden including Worker's Comp. Ins., Other Ins., FICA, Unemployment etc.

4. EXCLUSIONS: SEE COVER LETTER

5. PRICE QUALIFICATION : Because of current supply chain challenges, most construction products are subject to delayed delivery times and unusual price volatility due to conditions that are beyond of the General Contractor. Currently, we are unable to procure any future price obligations from the various subcontractors and manufacturers. As a result, we are unable to offer any price protection for this job. The pricing presented are based upon current material costs, which are subject to change at any time. CONSYS, Inc is doing their best to mitigate these issues, but we can't be held responsible for the cost or material delivery impacts that are beyond our control. If there is an increase in the cost of the products between when the project is bid and when the work is performed, the amount of the contract may increase to reflect the additional costs being incurred. If product delivery issues or material increases occur, we will provide proper notification and documentation to support any claims submitted.

TJS FENCE LLC

Fence Division
905 S bruce st
tampa fl 33606

invoice

DATE:	8/2/24
INVOICE #	8224
Customer ID	0.000

Customer: CONSYS, Inc
732 Kennedy ST NW
Washington, DC
20011

DESCRIPTION	AMOUNT
Change orders on the UDC project which include - Chain link fabric from 8 gauge to 6 gauge \$8350.00 [REDACTED] [REDACTED] [REDACTED]	[REDACTED]

Contract Signatures

[REDACTED]

SUBTOTAL	\$ [REDACTED]
TAX RATE	0.000%
TAX	\$ -
TOTAL	\$ [REDACTED]

Make all checks payable to
TJS FENCE LLC AND
MAILED TO 905 S Bruce St
tampa fl 33606

If you have any questions about this invoice, please contact

Thank You For Your Business!



CONTRACT NO.: GF-2020-C-0036

PROJECT NAME: UDC – Replace Natural Grass Athletic Field with Synthetic Turf

ATTACHMENT A - BCD 1 Back-up – Item No. 13

2502 Martin Luther King Junior Avenue, SE Washington, DC 20020
Office: (202) 545-1333; Fax: (202) 545-1339; e-mail: consys@consys-inc.net
www.consys-inc.net



June 11, 2024

VIA e-mail: eddie.whitaker@udc.edu
mgadson@udc.edu

Mr. Eddie Whitaker
Contracting Officer
The University of the District of Columbia
Office of Strategic Sourcing & Procurement
4200 Connecticut Avenue, NW
Building 39, Suite 200C
Washington, DC 20008

Re: Contract No. GF-2020-C-0036 – Replace Natural Grass Athletic Field with Synthetic Turf – PCR 030
Emergency Vehicle Ramp NW Concrete Work (RFI 039)

Mr. Whitaker:

Consys, Inc. hereby submits this PCR for having to complete the below mentioned work for a firm lump sum price of **\$148,578.47**

SCOPE OF WORK:

- F & I guard rail & railings for the NW Vehicle Ramp Access as per response to RFI 039
- Excavation, formwork, reinforcement and concrete work as per response to RFI 039
- Additional Site Grading and hauling of spoils
- Final clean-up of our area of work

We will need a 45-day time extension due to the shop drawing review, approval and fabrication of the railings and guard rails. We respectfully request you to review this PCR and issue us a necessary change order immediately for this added work that is being performed.

EXCLUSIONS:

- All permits and any utility deposit
- Excludes patching and repair of color concrete
- All structural support, roofing, architectural, mechanical, plumbing, sprinkler, architectural and FFE work
- All hazmat work

We, thank you once again for providing us the opportunity to submit this proposal. Our proposal is valid for a period of 30 days.

Consys, Inc. is a CBE & MDOT-MBE certified company.

If you need any further clarification, feel free to contact the undersigned at (202) 439-4123.

Sincerely,

Vijay R. Kasimsetty
Vice President

Cc: Alan Walsh, COTR and File

2502 Martin Luther King Junior Ave. SE Washington, DC 20020
Office: (202) 545-1333; Fax: (202) 545-1339; e-mail: consys@consys-inc.net
www.consys-inc.net



Construction Estimate

Project: GF-2020-C-0036, RNGAFwST - PCR 30 - Emergency Vehicle Ramp NW Concrete Work (RFI 039)

Item No.	Description	Unit	Quantity	Material	Material Costs	Labor Rate	Hours	Labor Costs	Equipment	Line Total	Subcontractor	Remarks
1	Site Concrete - NW Vehicle Access Ramp	job	1		\$ -			\$ -		\$ -	\$54,378.00	See attached proposal
2	Railings & Guard Rails	Job	1	\$ 35,899.00	\$ 35,899.00	\$ 115.00	80	\$ 9,200.00	\$ 650.00	\$ 45,749.00		In-house, See attached material quote
3	Surveyor	Job	1		\$ -			\$ -		\$ -	\$3,300.00	three trips at \$1,100.00 per trip
4	Additional Site Grading	Job	1		\$ -	\$ 65.00	80	\$ 5,200.00	\$ 2,500.00	\$ 7,700.00		In-house
5	Haul Spoils	CY	50	\$ 105.00	\$ 5,250.00			\$ -	\$ 2,500.00	\$ 7,750.00		
6					\$ -			\$ -		\$ -		
7					\$ -			\$ -		\$ -		
8					\$ -			\$ -		\$ -		
9					\$ -			\$ -		\$ -		
10					\$ -			\$ -		\$ -		
11					\$ -			\$ -		\$ -		
12					\$ -			\$ -		\$ -		
13					\$ -			\$ -		\$ -		
14	Project Coordination	Job			\$ -	\$ 175.00	33	\$ 5,775.00		\$ 5,775.00		
15	Disposal of all trash	Job			\$ -			\$ -		\$ -		
16	Site clean-up	Job			\$ -			\$ -		\$ -		
17	Senior Project Manager	Hrs			\$ -			\$ -		\$ -		
18	Project Manager	Hrs			\$ -			\$ -		\$ -		
19	Project Superintendent	Hrs			\$ -			\$ -		\$ -		
20	Skilled Laborer	Hrs			\$ -			\$ -		\$ -		
21	Dumpster	Job			\$ -			\$ -	\$ 950.00	\$ 950.00		
22					\$ -			\$ -		\$ -		
SUBTOTAL										\$ 67,924.00	\$ 57,678.00	
OH @ 10%										\$ 6,792.40	\$ -	
PROFIT @ 10%										\$ 6,792.40	\$ 5,767.80	
SUB TOTAL										\$ 81,508.80	\$ 63,445.80	
BOND & INSURANCE COST										\$ 2,037.72	\$ 1,586.15	
TOTAL										\$ 83,546.52	\$ 65,031.95	
GRAND TOTAL										\$	148,578.47	

1. The above proposal is valid as a lump sum and breakdown of individual task is for informational purposes only.

2. Equipment includes dump truck, dump fees, hauling costs, power tools such as saws, air compressors, safety equipment, hand tools, wheel barrows etc. (as applicable to the job).

3. Labor rates include labor burden including Worker's Comp. Ins, Other Ins., FICA, Unemployment etc.

4. EXCLUSIONS: SEE COVER LETTER

5. PRICE QUALIFICATION: Because of current supply chain challenges, most construction products are subject to delayed delivery times and unusual price volatility due to conditions that are beyond of the General Contractor. Currently, we are unable to procure any future price obligations from the various subcontractors and manufacturers. As a result, we are unable to offer any price protection for this job. The pricing presented are based upon current material costs, which are subject to change at any time. CONSYS, Inc is doing their best to mitigate these issues, but we can't be held responsible for the cost or material delivery impacts that are beyond our control. If there is an increase in the cost of the products between when the project is bid and when the work is performed, the amount of the contract may increase to reflect the additional costs being incurred. If product delivery issues or material increases occur, we will provide proper notification and documentation to support any claims submitted.

ADM Construction Inc.
 Concrete
 David P. Brady
 7724 Delano Road Clinton, Maryland 20735
 Office # (301) 856-7737 ❖ Fax # (301) 856-3965
 Email: admconcrete.const@gmail.com

Date: May 30, 2024

Proposal Submitted: Consys, Inc.		Phone: (202) 545-1333
Street: 732 Kennedy Street NW		Fax:
City: Washington	State: DC	Zip: 20011
Job Name: UDC Athletic Field	Job Phone:	
Job Location: 4200 Connecticut Avenue NW – Washington, DC 20008		
Architect:	Date of Plan:	

We hereby propose to furnish material and labor to complete in accordance with specifications below for the sum of:

Attention: Vijay Kasimsetty (vijay@consys-inc.net)
Payment to be made as follows: Net 30 days; 2% interest charged on balance due over 30 days; 24% per annum

Change Order #8:

<p>RFI 039:</p> <p>A-100: 8" Concrete pad 10' x 12" with 6" gravel base With #5 bars 12" OC EW Exclude removing spoils from site</p> <p>3' x 12" footing with #5 bars #12" OC Top and Bottom With #5 dowels 12" OC EF 12" concrete wall with a max height of 10' With #5 bars at 12" OC each way, each face</p> <p>Concrete stairs estimated 12 risers 6" rake with #5 bars at 12" OC EW with #4 bars continuous Backfill to install stairs Exclude any and all demo</p>	<p>\$ 54,378.00</p>
---	----------------------------

Signature of Acceptance Required _____

Date Signed _____



Change Order Request

Date: 6/5/24

COR #003

Submitted to: Vijay Kasimsetty
Vice President
Consys, Inc

Submitted by: Katie Thomas
Project Manager
Sightline Commercial Solutions

Project Name: UDC Van Ness Athletic Field North
Subject: As Built Modification + Vehicle Ramp
Reference:

Project No. 67525

Qty	UoM	Description	Unit Cost	Extended Price
1	LS	Vehicle Ramp + Stair HR	\$ 35,899.00	\$ 35,899.00

*Accounting breakout only, Both line items must be purchased together

*Remake scope: Does NOT include revised submittal, only As Built install set

Total USD \$

Contract Sum will be INCREASED By \$

Currently we are:

- Not proceeding with this work, pending written acceptance
- Proceeding with this work, please acknowledge this change by signing below

Accepted By

Customer Name

Sightline Commercial Solutions

Signature

Signature

Printed Name

Katie Thomas
Printed Name

Title

Project Manager
Title

Date

6/5/2024
Date



CONTRACT NO.: GF-2020-C-0036

PROJECT NAME: UDC – Replace Natural Grass Athletic Field with Synthetic Turf

ATTACHMENT A - BCD 1 Back-up – Item No. 14

2502 Martin Luther King Junior Avenue, SE Washington, DC 20020
Office: (202) 545-1333; Fax: (202) 545-1339; e-mail: consys@consys-inc.net
www.consys-inc.net



June 7, 2024

VIA e-mail: eddie.whitaker@udc.edu
mgadson@udc.edu

Mr. Eddie Whitaker
Contracting Officer
The University of the District of Columbia
Office of Strategic Sourcing & Procurement
4200 Connecticut Avenue, NW
Building 39, Suite 200C
Washington, DC 20008

Re: Contract No. GF-2020-C-0036 – Replace Natural Grass Athletic Field with Synthetic Turf – PCR 031 – ADA Ramp Rework (RFI 041)

Mr. Whitaker:

Consys, Inc. hereby submits this PCR for having to complete the below mentioned work for a firm lump sum price of **\$80,549.01**

SCOPE OF WORK:

- Additional Modifications to the railings as per response to RFI 041
- Additional concrete work as per response to RFI 041
- F & I drain board and drain tile as per response to RFI 041
- Final clean-up of our area of work

We respectfully request you to review this PCR and issue us a necessary change order for this added work that has to be performed.

EXCLUSIONS:

- All permits and any utility deposit
- Excludes patching and repair of color concrete
- All structural support, roofing, architectural, mechanical, plumbing, sprinkler, architectural and FFE work
- All hazmat work

We, thank you once again for providing us the opportunity to submit this proposal. Our proposal is valid for a period of 30 days.

Consys, Inc. is a CBE & MDOT-MBE certified company.

If you need any further clarification, feel free to contact the undersigned at (202) 439-4123.

Sincerely,

Vijay R. Kasimsetty
Vice President

Cc: Alan Walsh, COTR and File

2502 Martin Luther King Junior Ave. SE Washington, DC 20020
Office: (202) 545-1333; Fax: (202) 545-1339; e-mail: consys@consys-inc.net
www.consys-inc.net



Construction Estimate

Project: GF-2020-C-0036, RINGAFwST - PCR 31 - ADA Ramp Rework (RFI 041)

Item No.	Description	Unit	Quantity	Material	Material Costs	Labor Rate	Hours	Labor Costs	Equipment	Line Total	Subcontractor	Remarks
1	ADA Ramp Railing Rework	ea	1	\$ 40,977.00	\$ 40,977.00	\$ 115.00	40	\$ 4,600.00		\$ 45,577.00		
2	Drain Board and Drain Tile work	Job	1	\$ 1,250.00	\$ 1,250.00	\$ 65.00	80	\$ 5,200.00	\$ 1,250.00	\$ 7,700.00		In-house
3	Excavation for drain board and drain tile work	Job	1		\$ -	\$ 65.00	40	\$ 2,600.00		\$ 2,600.00		In-house
4	Additional Concrete work	Job	1		\$ -			\$ -		\$ -	\$6,220.00	See subcontractor proposal attached
5	Surveyor	Job	1		\$ -			\$ -		\$ -	\$1,100.00	One trip
6					\$ -			\$ -		\$ -		
7					\$ -			\$ -		\$ -		
8					\$ -			\$ -		\$ -		
9					\$ -			\$ -		\$ -		
10					\$ -			\$ -		\$ -		
11					\$ -			\$ -		\$ -		
12					\$ -			\$ -		\$ -		
13					\$ -			\$ -		\$ -		
14	Project Coordination	Job			\$ -	\$ 175.00	14	\$ 2,450.00		\$ 2,450.00		
15	Disposal of all trash	Job			\$ -			\$ -	\$ 450.00	\$ 450.00		
16	Site clean-up	Job			\$ -			\$ -		\$ -		
17	Senior Project Manager	Hrs			\$ -			\$ -		\$ -		
18	Project Manager	Hrs			\$ -			\$ -		\$ -		
19	Project Superintendent	Hrs			\$ -			\$ -		\$ -		
20	Skilled Laborer	Hrs			\$ -			\$ -		\$ -		
21	Dumpster	Job			\$ -			\$ -		\$ -		
22					\$ -			\$ -		\$ -		
SUBTOTAL										\$ 58,777.00	\$ 7,320.00	
OH @ 10%										\$ 5,877.70	\$ -	
PROFIT @ 10%										\$ 5,877.70	\$ 732.00	
SUB TOTAL										\$ 70,532.40	\$ 8,052.00	
BOND & INSURANCE COST										\$ 1,763.31	\$ 201.30	
TOTAL										\$ 72,295.71	\$ 8,253.30	
GRAND TOTAL										\$	80,549.01	

1. The above proposal is valid as a lump sum and breakdown of individual task is for informational purposes only.

2. Equipment includes dump truck, dump fees, hauling costs, power tools such as saws, air compressors, safety equipment, hand tools, wheel barrows etc. (as applicable to the job).

3. Labor rates include labor burden including Worker's Comp. Ins, Other Ins., FICA, Unemployment etc.

4. EXCLUSIONS: SEE COVER LETTER

5. PRICE QUALIFICATION: Because of current supply chain challenges, most construction products are subject to delayed delivery times and unusual price volatility due to conditions that are beyond of the General Contractor. Currently, we are unable to procure any future price obligations from the various subcontractors and manufacturers. As a result, we are unable to offer any price protection for this job. The pricing presented are based upon current material costs, which are subject to change at any time. CONSYS, Inc is doing their best to mitigate these issues, but we can't be held responsible for the cost or material delivery impacts that are beyond our control. If there is an increase in the cost of the products between when the project is bid and when the work is performed, the amount of the contract may increase to reflect the additional costs being incurred. If product delivery issues or material increases occur, we will provide proper notification and documentation to support any claims submitted.



Change Order Request

Date: 6/5/24

COR #003

Submitted to: Vijay Kasimsetty
Vice President
Consys, Inc

Submitted by: Katie Thomas
Project Manager
Sightline Commercial Solutions

Project Name: UDC Van Ness Athletic Field North
Subject: **As Built Modification** + Vehicle Ramp
Reference:

Project No. 67525

Qty	UoM	Description	Unit Cost	Extended Price
1	LS	As Built Modifications	\$ 40,977.00	\$ 40,977.00
1	LS	Vehicle Ramp + Stair HR	\$ 35,899.00	\$ 35,899.00

***Accounting breakout only, Both line items must be purchased together**

***Remake scope: Does NOT include revised submittal, only As Built install set**

Total USD \$ 76,876.00

Contract Sum will be INCREASED By \$ 76,876.00

Currently we are:

- Not proceeding with this work, pending written acceptance
- Proceeding with this work, please acknowledge this change by signing below

Accepted By

Customer Name

Sightline Commercial Solutions

Signature

Signature

Printed Name

Katie Thomas
Printed Name

Title

Project Manager
Title

Date

6/5/2024
Date

ADM Construction Inc.
Concrete
David P. Brady
7724 Delano Road Clinton, Maryland 20735
Office # (301) 856-7737 ❖ Fax # (301) 856-3965
Email: admconcrete.const@gmail.com

Date: May 17, 2024

Proposal Submitted: Consys, Inc.		Phone: (202) 545-1333
Street: 732 Kennedy Street NW		Fax:
City: Washington	State: DC	Zip: 20011
Job Name: UDC Athletic Field	Job Phone:	
Job Location: 4200 Connecticut Avenue NW – Washington, DC 20008		
Architect:		Date of Plan:

We hereby propose to furnish material and labor to complete in accordance with specifications below for the sum of:

Attention: Vijay Kasimsetty (vijay@consys-inc.net)
Payment to be made as follows: Net 30 days; 2% interest charged on balance due over 30 days; 24% per annum

Change Order #7:

<p>RFI 041: Ramp Wall</p> <p>Adm will increase the top of the wall as shown in RFI 041 max height increase is 2'</p> <p>Added rebar to extend to new top of wall</p> <p>Price includes labor and materials</p> <p>Concrete: 4 cy x \$350.00/cy = \$1,400.00 Rebar: 32 bars x \$15.00/bar = \$480.00 Form work: 80 sqf x \$5.50/sqf = \$440.00 Labor: 3 men x 10 hours x 2 days x \$65.00/hour = \$3,900.00</p>	\$ 6,220.00
--	--------------------

Signature of Acceptance Required _____ \

Date Signed _____



RFI RESPONSE

PROJECT:	UDC Van Ness Athletic Facilities Upgrade	SUBJECT:	New Sketch for ADA Ramp Clarification
QE #:	31607200		
CLIENT #:		RFI ID:	UDC VN - RFI 041
FROM:	Christine Cho - chris.cho@quinnevans.com	RFI TYPE:	Construction
TO:	Vijay Kasimsetty - vijay@consys-inc.net	DATE SENT:	5/16/2024

QUESTION:

ANSWER:

CONTENTS:

DATED:	TITLE:
5/16/2024	UDC VN - RFI 041.1R New Sketch for ADA Ramp Clarification - MA QE resp.pdf

DISTRIBUTION:

Lisa Sleith - lisa.sleith@udc.edu
Michael Huynh - mhuyh@mcmse.com



REQUEST FOR INFORMATION

To: Quinn Evans Architects RFI No: 041 Date: 05/13/2024
Attn: Christine Cho Contract No.: GF-2020-C-0036
For: Information/Action Title: New Sketch for ADA Ramp Clarification.
From: Vijay Kasimsetty
cc: Joanna Edwards, Alan Walsh, Lisa Sleith, Surinder Khanna, Ronald Alvarenga, and File

REPLY NEEDED BY: 05/14/2024.

QUESTIONS:

As per our discussion from the field visit on 05/07/24 with UDC and Consys, we will follow the sketch shown in the attachment for the new ADA Ramp. Please clarify and advise. (see attachments).

Please review and respond as soon as possible. Additional cost may be associated with this RFI. If any additional clarification is needed, feel free to contact the undersigned at (202) 439-4123.

Vijay R. Kasimsetty

Vijay R. Kasimsetty
Vice President

Copy to: Job File

REPLY:

Date: 5/14/24

Name: _____

Title: _____

SEE PAGE FOR FOLLOWING
COMMENTS

- MA

SEE SKETCH SK-02 FOR ADDITIONAL INFORMATION

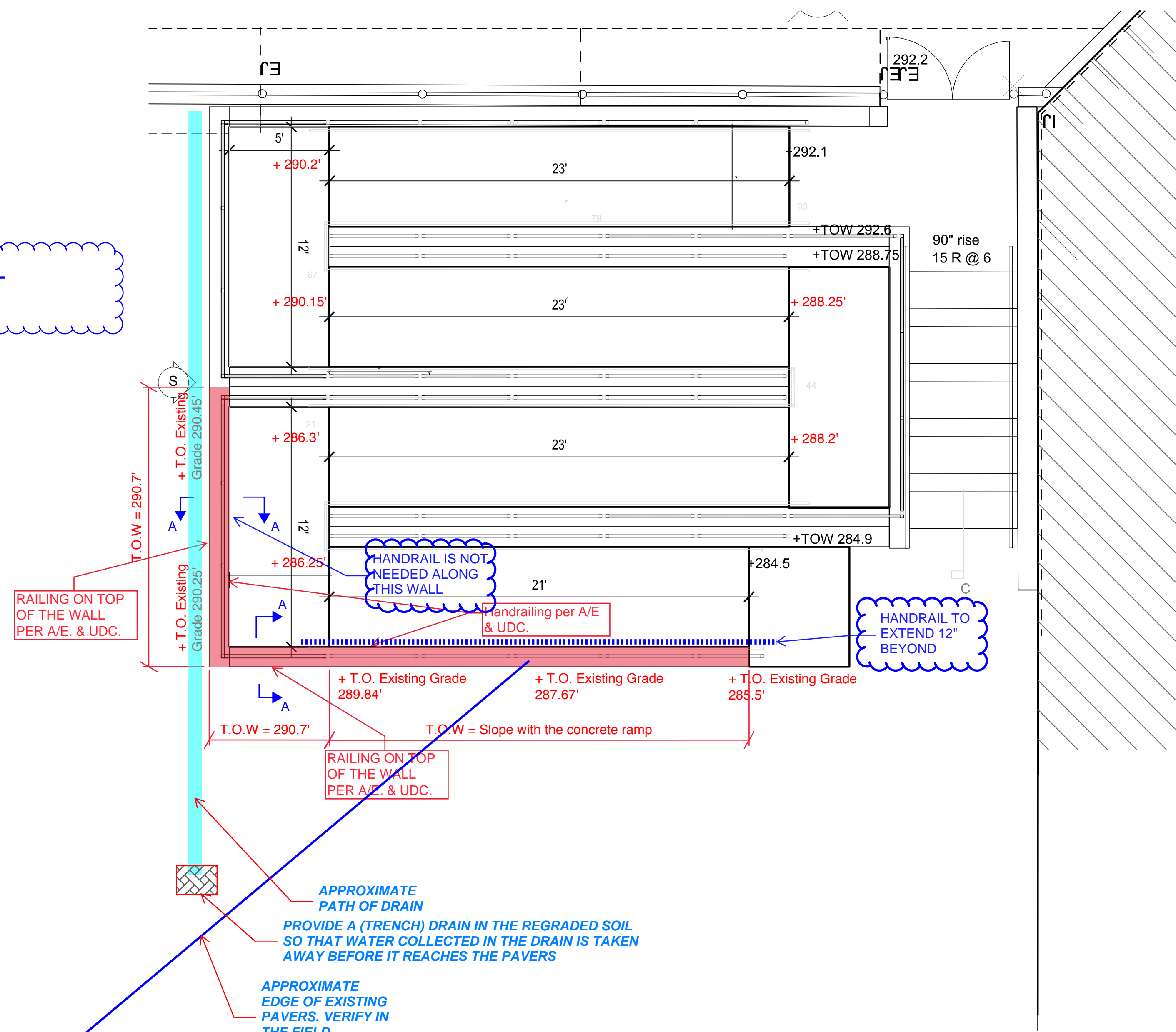

DCRA STAMP



2121 WARD PLACE, NW
4TH FLOOR
WASHINGTON, DC 20037
v 202 298 6700
f 202 298 6868
WWW.QUINNEVANS.COM

STAMP

JDC VAN NESS
ATHLETIC
FIELDS-
NORTH

4200 CONNECTICUT AVE NW
BUILDING 38, SUITE C01
WASHINGTON, DC 20008
QEA # 31607200
OWNER #
GF-2013-C-0114-C04-T0002

RAMP
DETAILS

ASI 2.1 07/17/23

REVISIONS		
NO.	DESCRIPTION	DATE
REV2	ASI 2.1	7/17/23

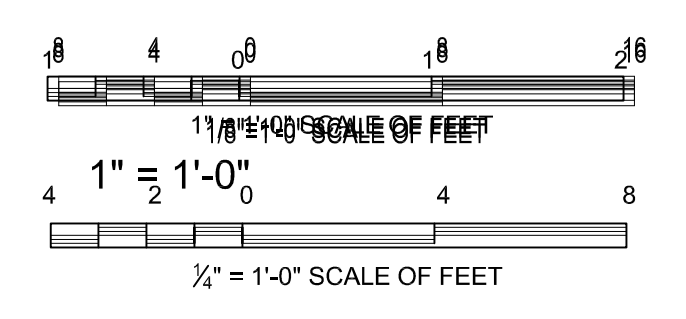

A110

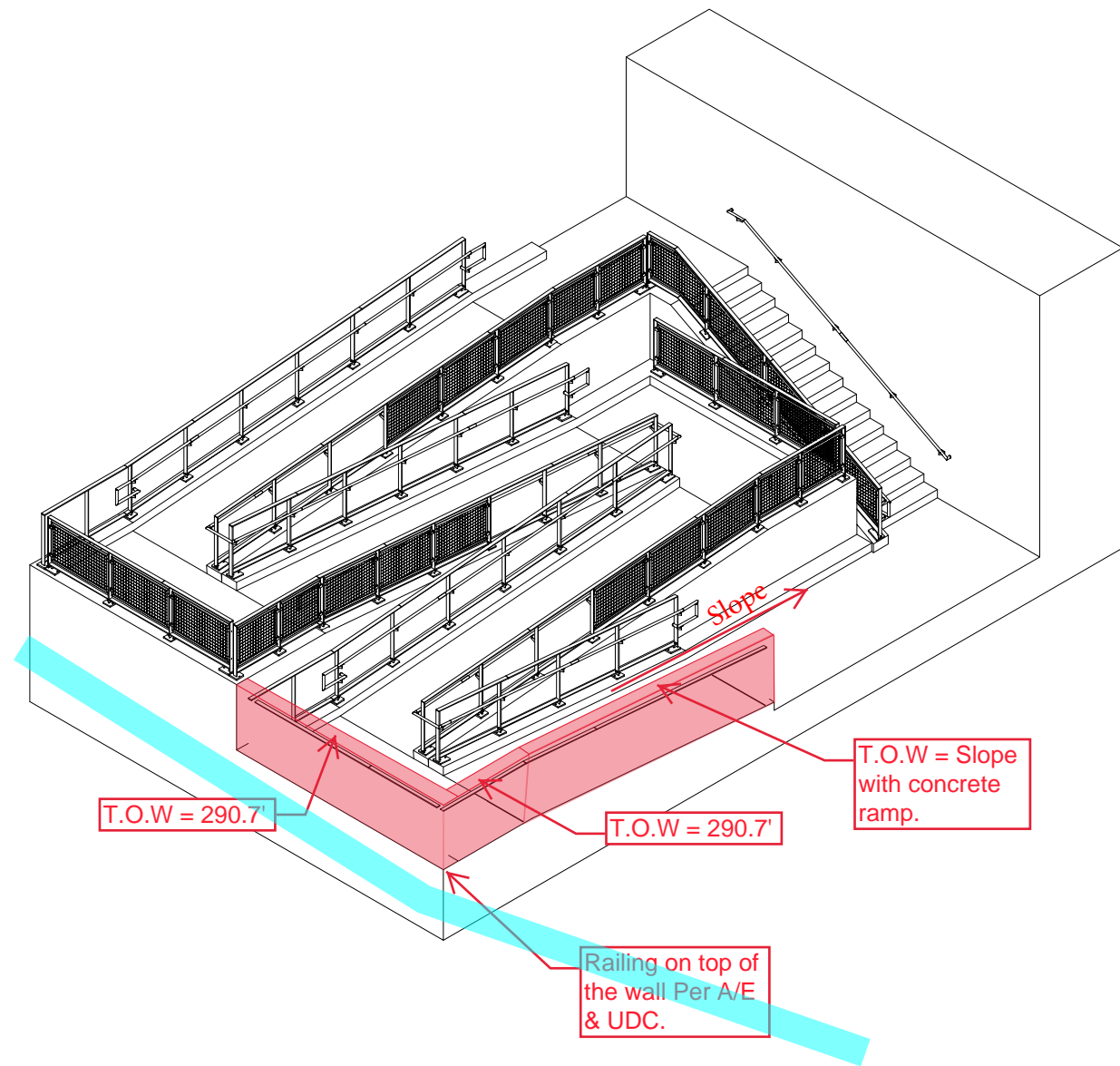

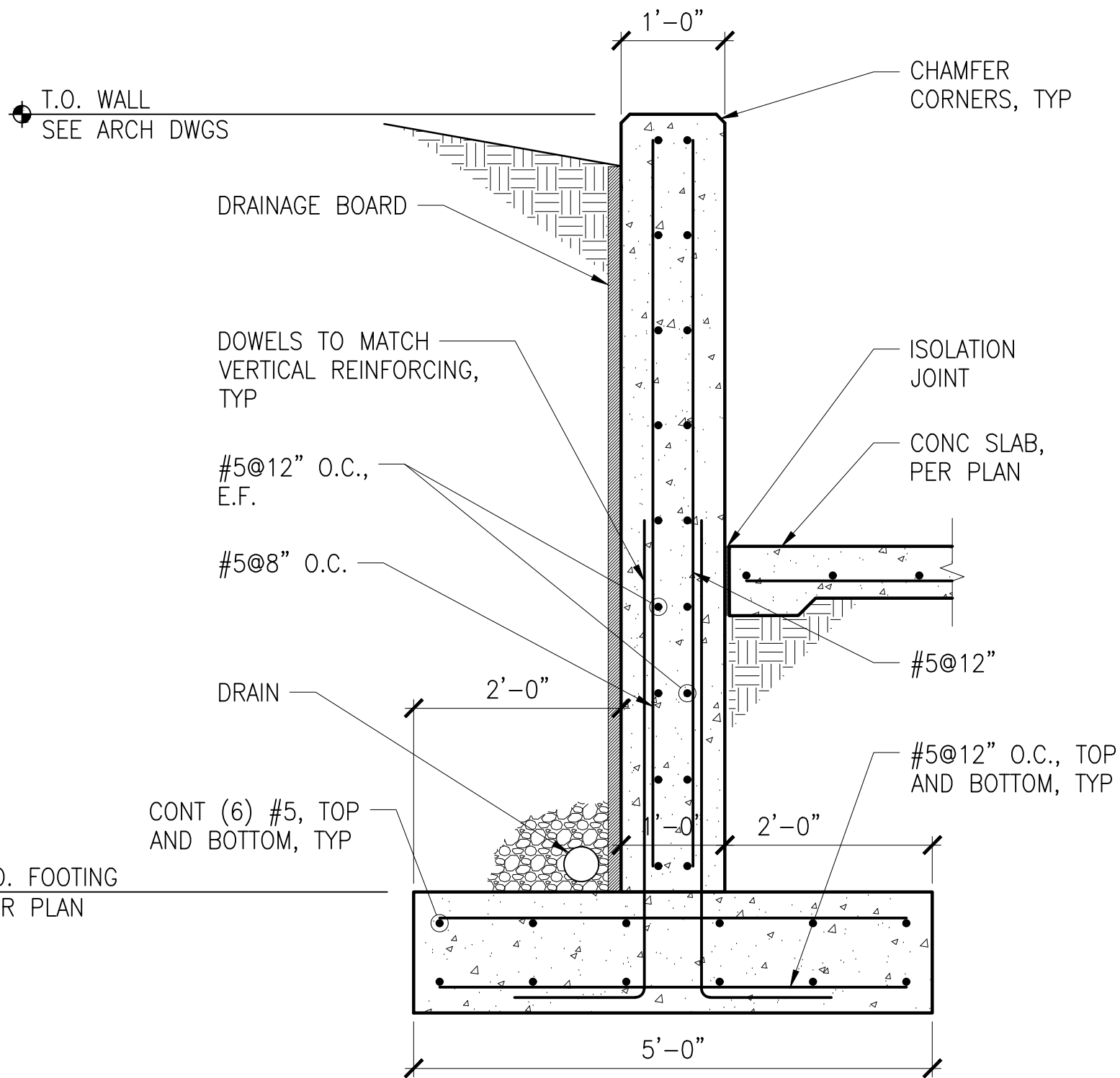

SECTION A-A

NOTES:

1. COORDINATE WALL LOCATIONS AND ELEVATIONS WITH ARCHITECTURAL DRAWINGS.
2. SEE 2/S302 FOR ADDITIONAL INFORMATION REGARDING DRAIN, DRAINAGE BOARD, AND WEEP HOLES.



CONTRACT NO.: GF-2020-C-0036

PROJECT NAME: UDC – Replace Natural Grass Athletic Field with Synthetic Turf

ATTACHMENT A - BCD 1 Back-up – Item No. 15

2502 Martin Luther King Junior Avenue, SE Washington, DC 20020
Office: (202) 545-1333; Fax: (202) 545-1339; e-mail: consys@consys-inc.net
www.consys-inc.net



June 26, 2024

VIA e-mail: eddie.whitaker@udc.edu
mgadson@udc.edu

Mr. Eddie Whitaker
Contracting Officer
The University of the District of Columbia
Office of Strategic Sourcing & Procurement
4200 Connecticut Avenue, NW
Building 39, Suite 200C
Washington, DC 20008

Re: Contract No. GF-2020-C-0036 – Replace Natural Grass Athletic Field with Synthetic Turf – PCR 32 - Geothermal Piping Repairs (RFI 38 Response) REV

Mr. Whitaker:

Consys, Inc. hereby submits this PCR for having to complete the below mentioned work for a firm lump sum price of **\$118,685.51.**

SCOPE OF WORK:

- Provide additional construction services for the geothermal pipe relocation as per RFI Response 38
- Final clean-up of our area of work

We respectfully request you to review this PCR and issue us a necessary change order for this added work that has to be performed.

EXCLUSIONS:

- All permits and any utility deposit
- All mechanical, electrical, plumbing, sprinkler, architectural, FFE, access control and voice & data work
- All hazmat work

We, thank you once again for providing us the opportunity to submit this proposal. Our proposal is valid for a period of 30 days.

Consys, Inc. is a CBE & MDOT-MBE certified company.

If you need any further clarification, feel free to contact the undersigned at (202) 439-4123.

Sincerely,

Vijay R. Kasimsetty
Vice President

Cc: Joanna Edwards, Alan Walsh, COTR and File

2502 Martin Luther King Junior Avenue, SE Washington, DC 20020
Office: (202) 545-1333; Fax: (202) 545-1339; e-mail: consys@consys-inc.net
www.consys-inc.net



Construction Estimate

Project: GF-2020-C-0036, RNgAFwST - PCR 32 Geothermal Piping Lowering (RFI 38 Response) REV 062624

Item No.	Description	Unit	Quantity	Material	Material Costs	Labor Rate	Hours	Labor Costs	Equipment	Line Total	Subcontractor	Remarks
1	James Wheat & Sons	Job	1		\$ -			\$ -		\$ -	\$125.00	See attached quote
2	Limbach	job	1		\$ -			\$ -		\$ -	\$23,839.80	See subcontractors Invoice
3	Allied (Patching)	job	1		\$ -			\$ -		\$ -	\$9,750.00	See subcontractors quote
4	Furnish Additional Glycol	Job	1	\$ 1,260.10	\$ 1,260.10	\$ 95.00	4	\$ 380.00		\$ 1,640.10		
5	Allied (Pipe Relocation Work)	Job	1		\$ -			\$ -		\$ -	\$28,290.00	See subcontractors quote
6	Expose lines and Sand bedding	Job	1	\$ 1,300.00	\$ 1,300.00	\$ 65.00	60	\$ 3,900.00	\$ 2,500.00	\$ 7,700.00		In-house
7	Disposal of spoils	Job	1		\$ -	\$ 65.00	80	\$ 5,200.00	\$ 3,600.00	\$ 8,800.00		4 trucks
8	Environmental Testing	Job	1		\$ -			\$ -		\$ -	\$7,979.40	See attached Vendor Invoices
9					\$ -			\$ -		\$ -		
10	Project Coordination	Job			\$ -	\$ 175.00	40	\$ 7,000.00		\$ 7,000.00		
11	Disposal of all trash	Job			\$ -			\$ -		\$ -		
12	Site clean-up	Job			\$ -	\$ 45.00	20	\$ 900.00		\$ 900.00		
13	Senior Project Manager	Hrs			\$ -			\$ -		\$ -		
14	Project Manager	Hrs	20		\$ -	\$ 125.00	20	\$ 2,500.00		\$ 2,500.00		
15	Project Superintendent	Hrs	40		\$ -	\$ 95.00	40	\$ 3,800.00		\$ 3,800.00		
16	Skilled Laborer	Hrs			\$ -			\$ -		\$ -		
17	Dumpster	Job			\$ -			\$ -		\$ -		
18					\$ -			\$ -		\$ -		
19					\$ -			\$ -		\$ -		
SUBTOTAL										\$ 32,340.10	\$ 69,984.20	
OH @ 10%										\$ 3,234.01	\$ -	
PROFIT @ 10%										\$ 3,234.01	\$ 6,998.42	
SUB TOTAL										\$ 38,808.12	\$ 76,982.62	
BOND & INSURANCE COST										\$ 970.20	\$ 1,924.57	
TOTAL										\$ 39,778.32	\$ 78,907.19	
GRAND TOTAL										\$	118,685.51	

1. The above proposal is valid as a lump sum and breakdown of individual task is for informational purposes only.

2. Equipment includes dump truck, dump fees, hauling costs, power tools such as saws, air compressors, safety equipment, hand tools, wheel barrows etc. (as applicable to the job).

3. Labor rates include labor burden including Worker's Comp. Ins, Other Ins., FICA, Unemployment etc.

4. EXCLUSIONS: SEE COVER LETTER

5. PRICE QUALIFICATION : Because of current supply chain challenges, most construction products are subject to delayed delivery times and unusual price volatility due to conditions that are beyond of the General Contractor. Currently, we are unable to procure any future price obligations from the various subcontractors and manufacturers. As a result, we are unable to offer any price protection for this job. The pricing presented are based upon current material costs, which are subject to change at any time. CONSYS, Inc is doing their best to mitigate these issues, but we can't be held responsible for the cost or material delivery impacts that are beyond our control. If there is an increase in the cost of the products between when the project is bid and when the work is performed, the amount of the contract may increase to reflect the additional costs being incurred. If product delivery issues or material increases occur, we will provide proper notification and documentation to support any claims submitted.

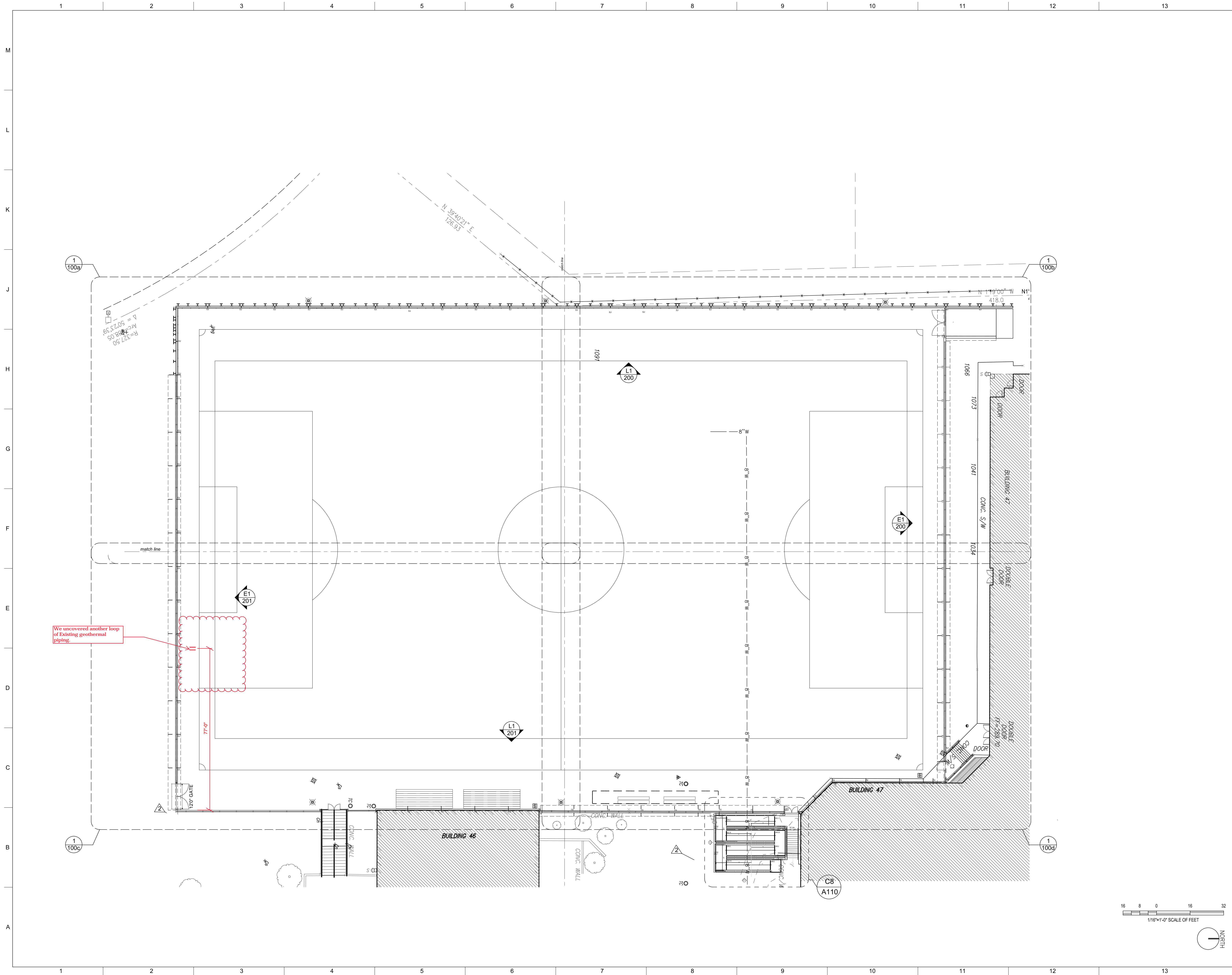

DCRA STAMP



2121 WARD PLACE, NW
4TH FLOOR
WASHINGTON, DC 20037
v 202 298 6700
f 202 298 6868
WWW.QUINNEVANS.COM

STAMP

UDC VAN NESS ATHLETIC FIELDS-NORTH

4200 CONNECTICUT AVE NW
BUILDING 38, SUITE C01
WASHINGTON, DC 20008
QEA # 31607200
OWNER # GF-2013-C-0114-C04-T0002

SITE PLAN NEW WORK OVERALL

ASI 2.1 07/17/23

REVISIONS		
NO.	DESCRIPTION	DATE
REV2	ASI 2.1	7/17/23

A100



Project: UDC - Replace Natural Grass Athletic Field With Synthetic Turf

Photographic Documentation

2502 Martin Luther King Jr. Avenue SE, Washington, DC 20020
Office: (202) 545-1333; Fax: (202) 545-1339; e-mail: consys@consys-inc.net
www.consys-inc.net

UDC - UDC - Replace Natural Grass Athletic Field With Synthetic Turf

Building 47:

Location: Athletic Field - Building 47
South East Elevation





James A Wheat & Sons
 7834 Beechcraft Ave, Gaithersburg,
 Maryland 20879
 www.wheatandsons.com

BILL TO

University of the District of Columbia
 4200 Connecticut Avenue Northwest
 Washington, DC 20008 USA

INVOICE 662822	INVOICE DATE 4/25/2024
--------------------------	----------------------------------

JOB ADDRESS

University of the District of Columbia
 4200 Connecticut Avenue Northwest
 Washington, DC 20008 USA

Completed Date
Customer PO #
Payment Term Due Upon Receipt

DESCRIPTION OF WORK

Today I located the athletic field that was currently being renovated. One of the geothermal loop lines was cut, which caused the loop to drain and empty. After determining the scope of the work and called the manger, this issue would be able to befixed by Allied, a company we refer underground loop repairs. The manager will be contacting the project manager to give the contact information for Allied (Wes is the POC at Allied). I also attached the fluid specification document that was sent to me by the project manager on site. I collected he diagnostic fee for today using the card onfile. Thank you for choosing James James A. Wheat & Sons.

* see back notes

TASK	DESCRIPTION	QTY	PRICE	TOTAL
J600002	Diagnostic / 1st Repair - Air Conditioning Cycle. Thorough inspection of the air conditioning system included refrigerant charge, compressor amps, temperature readings, air flow pressure readings, motor amp readings, capacitor readings and more. Includes removal of blower motor to check cleanliness of motor and indoor coils. Includes clean up of debris from any repairs made.	1.00	\$125.00	\$125.00

PAYMENT

Paid On	Type	Memo	Amount
4/25/2024	AMEX		\$125.00
		SUB-TOTAL	\$125.00
		TAX 0%	\$0.00
		TOTAL DUE	\$125.00
		PAYMENT	\$125.00
		BALANCE DUE	\$0.00

Thank you for choosing James A Wheat & Sons. Please use the following link to access our payment portal-
<https://jamesawheat.securepayments.cardpointe.com/pay>

CUSTOMER AUTHORIZATION

I, the Owner or Owner's agent, have authorization to approve the work attached to be performed at 4200 Connecticut Avenue Northwest, Washington, DC 20008 USA and further agree to the terms, Terms and Conditions, and amount of repairs \$125.00. I understand that payment is due in full upon completion of the approved work. A service fee of \$45 will be charged for any returned checks. A finance charge of 1% per month shall be applied for all overdue amounts .

Sign here

Date

CUSTOMER ACKNOWLEDGEMENT

I find and agree that all work performed by James A Wheat & Sons has been completed in a satisfactory and workmanlike manner. I have been given the opportunity to address concerns and/or discrepancies in the work provided, and I either have no such concerns or have found no discrepancies or they have been addressed to my satisfaction. My signature here signifies my full and final acceptance of all work performed by the contractor. Please use the following link to access our payment portal-
<https://jamesawheat.securepayments.cardpointe.com/pay>

Sign here

Date

I authorize James A Wheat & Sons to charge the agreed amount to my credit card provided herein. I agree that I will pay for this purchase in accordance with the issuing bank cardholder agreement.



Sign here

Date 4/25/2024



Limbach Company LLC- Mid Atlantic
 3915 National Drive
 Burtonsville, MD 20866

INVOICE

INVOICE #: 21437

INVOICE DATE: 04/30/2024

DUE DATE: 05/30/2024

CUSTOMER NUMBER: 171691

CONSYS INC

2502 MARTIN LUTHER KING JUNIOR
 AVE SE
 WASHINGTON, DC 20020

RE: SERVICE PERFORMED AT

UDC BLDG 56
 4200 CONNECTICUT AVE NW
 WASHINGTON, DC 20008

ATTN:

WORK ORDER NUMBER: 38370 **P.O. NUMBER:**

Problem Description: GLYCOL REFILL

Visit Resolution: Mon. 4/29/24: Received the call that geothermal loop repairs had been made. Drove to Morin Distribution with Nick to pick up 150 gallons of Dowfrost 35 glycol mixture. Arrived on site and gained access to mechanical room. Pumped in glycol and system still needs more, pumped in 75 gallons provided by contractor, went back to Morin Distribution and got another 150 gallons, returned to site and pumped it into the loop and it still not enough..... but system will run overnight. Tue. 4/30/24: Went to Morin Distribution for another 150 gallons, returned to GWU, gained access to mechanical room and pumped another 90 gallons in before pressure set point was satisfied. Left 60 gallons on site in mechanical room.

Labor

DETWILER, RICHARD	04/30/24	5.000 @	190.00	950.00
BOCCHI, NICHOLAS	04/30/24	5.000 @	190.00	950.00
DETWILER, RICHARD	04/29/24	8.000 @	190.00	1520.00
BOCCHI, NICHOLAS	04/29/24	8.000 @	190.00	1520.00
DETWILER, RICHARD	04/29/24	1.000 @	269.00	269.00
BOCCHI, NICHOLAS	04/29/24	1.000 @	269.00	269.00
Net Labor:				5478.00

Misc Expense

Truck Non-Contract	3.000 @	75.00	225.00
Net Misc Expense:			225.00

Purchased Materials

Non-Inventory Materials	10891.14
Net Purchased Materials:	10891.14

Work Order Total:	16,594.14
Sales Tax:	653.47
Total Invoice:	17,247.61

THANK YOU FOR YOUR BUSINESS!

Invoice questions or concerns? Please call 301-623-4800.

Credit card transactions are subject to an additional 2.75% fee. To pay via credit card, please use t [LINK](#)

For **ACH and Domestic wires**, please utilize the following information:

Remittances to ACHRemittances@limbachinc.com

Wheaton Bank & Trust Co., N. A.
100 North Wheaton Avenue
Wheaton, IL 60187
Transit/Routing Number: 071925389

Beneficiary: Limbach Facility Services, LLC - Main Operating Account
Account Number: 2916241061



Limbach Company LLC- Mid Atlantic
 3915 National Drive
 Burtonsville, MD 20866

INVOICE

INVOICE #: 21618

INVOICE DATE: 05/31/2024

DUE DATE: 06/30/2024

CUSTOMER NUMBER: 171691

CONSYS INC
 2502 MARTIN LUTHER KING JUNIOR
 AVE SE
 WASHINGTON, DC 20020

RE: SERVICE PERFORMED AT
 UDC BLDG 56
 4200 CONNECTICUT AVE NW
 WASHINGTON, DC 20008

ATTN:

WORK ORDER NUMBER: 38567 **P.O. NUMBER:**

Problem Description: GLYCOL

Visit Resolution: Mon. 5/20/24: Arrived on site, checked in with CONSYS contact Vyjay and Clifford (UDC Engineer) gained access to mechanical room, found water in glycol makeup tank, drained water from tank, pumped in 45 gallons (on site). Gathered 8 empty 15 gallon jugs. Went to supply house and picked up 120 gallons 35% glycol solution, returned to UDC. Filled glycol makeup tank with an additional 45 gallons and left 75 gallons (five 15 gallon jugs) in mechanical room. Check and verify proper equipment operation. Called both Clifford and Vyjay to inform them of situation.

Labor

DETWILER, RICHARD	05/20/24	8.000 @	190.00	1520.00
ENSOR, RONNIE	05/20/24	8.000 @	190.00	1520.00
Net Labor:				3040.00

Purchased Materials

Non-Inventory Materials	3351.12
Net Purchased Materials:	3351.12

Work Order Total: 6,391.12

Sales Tax: 201.07

Total Invoice: 6,592.19

THANK YOU FOR YOUR BUSINESS!

Invoice questions or concerns? Please call 301-623-4800.

Credit card transactions are subject to an additional 2.75% fee. To pay via credit card, please use this

[LINK](#)



Laurel, MD - Sinking Spring, PA - New Paltz, NY
Fayetteville, GA - Prince Frederick, MD
www.alliedwells.com

Apr 26, 2024

RE: Damaged Geothermal Pipe Repair - UDC

Good morning Vijay, below is the cost for a lateral crew from Allied to come on Saturday 4/27/24 to make the necessary repairs to the 2" HDPE geothermal underground piping.

Base Price for Mobilization & Repair for (1) 3-man crew: \$8,500

Saturday O.T. cost: \$1,250

Total Cost: **\$9,750**

Thank you,

Anthony Ghoubril
Commercial Project Manager
Allied Environmental Service, INC.

Signature: _____

Date: _____



Laurel, MD - Sinking Spring, PA - New Paltz, NY
Fayetteville, GA - Prince Frederick, MD
www.alliedwells.com

May 3, 2024

RE: UDC - Geothermal Piping Elevation Design Change Proposal

Dear Consys, Inc. Project Team,

Please find the proposal to perform the requested geothermal rework to correct the elevations of the geothermal supply and return main piping in the new Athletic Field located at 4200 Connecticut Ave., NW Building 38, Suite C01 Washington, DC 20008 in the amount of \$28,290.00. The below proposal breakdown is for the rework requested in RFI 036 for Contract # GF-2020-C-0036 - Geothermal Pipe above Finish Elevation Clarification. This proposal is for the required material, labor, equipment time, etc. to complete this rework. This proposal includes the excavation to a maximum depth of 6'-0", the hand excavation of (2) - 6 Well Circuits, removal of (2) - 6 Well Circuits, temporary capping of Geothermal Well/Piping, and reinstallation of horizontal piping once required elevations have been achieved. This proposal does not include any additional excavation, rock excavation, trench preparation or compaction, etc. This additional time does not include overtime, weekend work, night work or additional labor not specifically outlined in the attached proposal breakdown.

Please see the attached proposal breakdown. Please note that this does not include any additional work/time/materials/equipment not specifically outlined in this proposal. This proposal does not include any flushing, purging or pressure testing procedures. If these services are requested, an additional proposal will be presented.

Please contact me with any questions.

Thank you,

Melanie Judd
Director of Commercial Project Management
Allied Well Drilling

Signature: _____

Date: _____

UDC - North Athletic Field
 Washington, DC
 Geothermal Rework Proposal
 Elevation Change



P.O. Box 129
 Annapolis Junction, MD 20701
 P) 301-776-8370 F) 301-773-8374
www.alliedwells.com

5/3/2024

Horizontal Hook-up & Excavation				
Materials				
Includes:	Unit Price:	Qty:	Unit:	Total:
All Fittings, HDPE piping, bedding, etc.	\$3,750.00	1	Lump Sum	\$ 3,750.00
Total Drill Materials				\$ 3,750.00
Labor				
Includes:	Rate:	Hours:		Total:
Superintendent	\$85.64	40		\$ 3,425.50
Fusion Tech	\$54.81	40		\$ 2,192.50
Pipelayer	\$44.34	40		\$ 1,773.50
Pipelayer	\$44.34	40		\$ 1,773.50
<u>Unit Price</u>	<u>Qty</u>	<u>Desc.</u>		Total
\$229.13	40	Hours		\$ 9,165.00
Horizontal Hook Up Equipment				
Includes:	Rate:	Unit:		Total:
Excavator	\$300.00	day	5	\$1,500.00
W. Roller	\$200.00	day	5	\$1,000.00
Fusion Equip	\$250.00	day	5	\$1,250.00
Confined Space	\$1,000.00	day	5	\$5,000.00
Total	\$1,750.00			
Equipment	<u>Hourly Rate</u>	<u>Qty/Hr</u>	<u>Desc.</u>	Total
	\$218.75	40.00	Hrs	\$ 8,750.00
Hookup Fuel				
<u>Daily Rate</u>	<u>Hourly Rate</u>	<u>Qty</u>	<u>Desc.</u>	Total
\$325.00	\$40.63	40	Gallons	\$ 1,625.00

Totals	
H/U labor	\$ 9,165.00
H/U mat'l	\$ 3,750.00
H/U equip	\$ 8,750.00
Fuel	\$ 1,625.00
Mobilization	\$ 5,000.00
Tax	\$ -
Subtotal	\$ 28,290.00
Admin	\$ -
Total	\$ 28,290.00

Approved by:

Name:
Signature:
Title:
Date:

Adams Environmental Engineering Group, LLC
 8055 Ritchie Highway, Suite 207
 Pasadena, MD 21122
 +1 4433057810
 info@adamsenvironmentaleng.net
 www.adamsenvironmentaleng.net

Invoice



BILL TO
 Consys Inc.
 PO Box 60825
 Washington, DC 20039 USA

SHIP TO
 4200 Connecticut Ave NW
 Washington, DC 20008

INVOICE #	DATE	TOTAL DUE	DUE DATE	TERMS	ENCLOSED
24-3945	05/08/2024	\$1,300.00	06/07/2024	Net 30	

JOB NUMBER
 243590

DATE	ACTIVITY	DESCRIPTION	QTY	RATE	AMOUNT
05/08/2024	Unit	Soil Sample Collection	1	500.00	500.00
	Unit	Soil Sample Analysis	1	800.00	800.00

Please remit payment to (NEW ADDRESS):
 Adams Environmental Engineering Group, LLC
 8055 Ritchie Highway, Suite 207
 Pasadena, MD 21122
 EIN #83-0869359

BALANCE DUE

\$1,300.00

Adams Environmental Engineering Group, LLC
 8055 Ritchie Highway, Suite 207
 Pasadena, MD 21122
 +1 4433057810
 info@adamsenvironmentaleng.net
 www.adamsenvironmentaleng.net

Invoice



BILL TO
 Consys Inc.
 PO Box 60825
 Washington, DC 20039 USA

SHIP TO
 4200 Connecticut Ave NW
 Washington, DC 20008

INVOICE #	DATE	TOTAL DUE	DUE DATE	TERMS	ENCLOSED
24-4086	06/25/2024	\$6,679.40	07/25/2024	Net 30	

JOB NUMBER
 243590

DATE	ACTIVITY	DESCRIPTION	QTY	RATE	AMOUNT
05/17/2024	Unit	Sampling	1	800.00	800.00
05/17/2024	Unit	Analytical	6	500.00	3,000.00
05/17/2024	Unit	Facility Approval	1	600.00	600.00
05/17/2024	Unit	Impacted Soil Disposal and Transportation	13.48	80.00	1,078.40
05/17/2024	Unit	Spill Report	1	500.00	500.00
05/17/2024	Unit	No load fee	1.10	350.00	385.00
05/17/2024	Unit	Manifest delivery	4	79.00	316.00

Please remit payment to (NEW ADDRESS):
 Adams Environmental Engineering Group, LLC
 8055 Ritchie Highway, Suite 207
 Pasadena, MD 21122
 EIN #83-0869359

BALANCE DUE

\$6,679.40



CONTRACT NO.: GF-2020-C-0036

PROJECT NAME: UDC – Replace Natural Grass Athletic Field with Synthetic Turf

ATTACHMENT A - BCD 1 Back-up – Item No. 16

2502 Martin Luther King Junior Avenue, SE Washington, DC 20020
Office: (202) 545-1333; Fax: (202) 545-1339; e-mail: consys@consys-inc.net
www.consys-inc.net



August 28, 2024

VIA e-mail: eddie.whitaker@udc.edu
mgadson@udc.edu

Mr. Eddie Whitaker
Contracting Officer
The University of the District of Columbia
Office of Strategic Sourcing & Procurement
4200 Connecticut Avenue, NW
Building 39, Suite 200C
Washington, DC 20008

Re: Contract No. GF-2020-C-0036 – Replace Natural Grass Athletic Field with Synthetic Turf – PCR 33 - F & I Seed and Straw (DOEE)

Mr. Whitaker:

Consys, Inc. hereby submits this PCR for having to complete the below mentioned work for a firm lump sum price of **\$24,907.50.**

SCOPE OF WORK:

- F & Install seed and straw on the secondary staging area / field DOEE enforcement
- Final clean-up of our area of work

We respectfully request you to review this PCR and issue us a necessary change order for this added work that has to be performed.

EXCLUSIONS:

- All permits and any utility deposit
- Excludes patching and repair of color concrete
- All structural support, roofing, architectural, mechanical, plumbing, sprinkler and FFE work
- All hazmat work

We, thank you once again for providing us the opportunity to submit this proposal. Our proposal is valid for a period of 30 days.

Consys, Inc. is a CBE & MDOT-MBE certified company.

If you need any further clarification, feel free to contact the undersigned at (202) 439-4123.

Sincerely,

Vijay R. Kasimsetty
Vice President

Cc: Alan Walsh, COTR and File

2502 Martin Luther King Junior Ave. SE Washington, DC 20020
Office: (202) 545-1333; Fax: (202) 545-1339; e-mail: consys@consys-inc.net
www.consys-inc.net



Construction Estimate

Project: GF-2020-C-0036, RNgAFwST - PCR 33 - F & I Seed and Straw (DOEE)

Item No.	Description	Unit	Quantity	Material	Material Costs	Labor Rate	Hours	Labor Costs	Equipment	Line Total	Subcontractor	Remarks
1	F & I straw and seeding of secondary staging area (DOEE)	Job	1	\$ 6,350.00	\$ 6,350.00	\$ 65.00	160	\$ 10,400.00	\$ 3,500.00	\$ 20,250.00		In-house
2					\$ -			\$ -		\$ -		
3					\$ -			\$ -		\$ -		
4					\$ -			\$ -		\$ -		
5					\$ -			\$ -		\$ -		
6					\$ -			\$ -		\$ -		
7					\$ -			\$ -		\$ -		
8					\$ -			\$ -		\$ -		
9					\$ -			\$ -		\$ -		
10					\$ -			\$ -		\$ -		
SUBTOTAL										\$ 20,250.00	\$ -	
OH @ 10%										\$ 2,025.00	\$ -	
PROFIT @ 10%										\$ 2,025.00	\$ -	
SUB TOTAL										\$ 24,300.00	\$ -	
BOND & INSURANCE COST										\$ 607.50	\$ -	
TOTAL										\$ 24,907.50	\$ -	
GRAND TOTAL										\$	24,907.50	

1. The above proposal is valid as a lump sum and breakdown of individual task is for informational purposes only.

2. Equipment includes dump truck, dump fees, hauling costs, power tools such as saws, air compressors, safety equipment, hand tools, wheel barrows etc. (as applicable to the job).

3. Labor rates include labor burden including Worker's Comp. Ins., Other Ins., FICA, Unemployment etc.

4. EXCLUSIONS: SEE COVER LETTER

5. PRICE QUALIFICATION : Because of current supply chain challenges, most construction products are subject to delayed delivery times and unusual price volatility due to conditions that are beyond of the General Contractor. Currently, we are unable to procure any future price obligations from the various subcontractors and manufacturers. As a result, we are unable to offer any price protection for this job. The pricing presented are based upon current material costs, which are subject to change at any time. CONSYS, Inc is doing their best to mitigate these issues, but we can't be held responsible for the cost or material delivery impacts that are beyond our control. If there is an increase in the cost of the products between when the project is bid and when the work is performed, the amount of the contract may increase to reflect the additional costs being incurred. If product delivery issues or material increases occur, we will provide proper notification and documentation to support any claims submitted.



CONTRACT NO.: GF-2020-C-0036

PROJECT NAME: UDC – Replace Natural Grass Athletic Field with Synthetic Turf

ATTACHMENT A - BCD 1 Back-up – Item No. 17

2502 Martin Luther King Junior Avenue, SE Washington, DC 20020
Office: (202) 545-1333; Fax: (202) 545-1339; e-mail: consys@consys-inc.net
www.consys-inc.net



May 31, 2024

VIA e-mail: eddie.whitaker@udc.edu
mgadson@udc.edu

Mr. Eddie Whitaker
Contracting Officer
The University of the District of Columbia
Office of Strategic Sourcing & Procurement
4200 Connecticut Avenue, NW
Building 39, Suite 200C
Washington, DC 20008

Re: Contract No. GF-2020-C-0036 – Replace Natural Grass Athletic Field with Synthetic Turf – PCR 34 – Synthetic Turf Acceleration Cost

Mr. Whitaker:

Consys, Inc. hereby submits this PCR for having to complete the below mentioned work for a firm lump sum price of **\$169,744.54.**

SCOPE OF WORK:

- Synthetic Turf Installation Accelerated Cost
- Final clean-up of our area of work

We respectfully request you to review this PCR and issue us a necessary change order for this added work that has to be performed.

EXCLUSIONS:

- All permits and any utility deposit
- All mechanical, electrical, plumbing, sprinkler, architectural, FFE, access control and voice & data work
- All hazmat work

We, thank you once again for providing us the opportunity to submit this proposal. Our proposal is valid for a period of 30 days.

Consys, Inc. is a CBE & MDOT-MBE certified company.

If you need any further clarification, feel free to contact the undersigned at (202) 439-4123.

Sincerely,

Vijay R. Kasimsetty
Vice President

Cc: Joanna Edwards, Alan Walsh, COTR and File

2502 Martin Luther King Junior Avenue, SE Washington, DC 20020
Office: (202) 545-1333; Fax: (202) 545-1339; e-mail: consys@consys-inc.net
www.consys-inc.net



Construction Estimate

Project: GF-2020-C-0036, RNgAFwST - PCR 34 - Synthetic Turf Acceleration

Item No.	Description	Unit	Quantity	Material	Material Costs	Labor Rate	Hours	Labor Costs	Equipment	Line Total	Subcontractor	Remarks
1	Field Turf - Acceleration	Job	1		\$ -			\$ -		\$ -	\$136,804.03	See attached quote
2					\$ -			\$ -		\$ -		
3					\$ -			\$ -		\$ -		
4					\$ -			\$ -		\$ -		
5					\$ -			\$ -		\$ -		
6					\$ -			\$ -		\$ -		
7					\$ -			\$ -		\$ -		
8					\$ -			\$ -		\$ -		
9					\$ -			\$ -		\$ -		
10	Overtime Hours	Job			\$ -	\$ 150.00	84	\$ 12,600.00		\$ 12,600.00		
11	Disposal of all trash	Job			\$ -			\$ -		\$ -		
12	Site clean-up	Job			\$ -			\$ -		\$ -		
13	Senior Project Manager	Hrs			\$ -			\$ -		\$ -		
14	Project Manager	Hrs			\$ -			\$ -		\$ -		
15	Project Superintendent	Hrs			\$ -			\$ -		\$ -		
16	Skilled Laborer	Hrs			\$ -			\$ -		\$ -		
17	Dumpster	Job			\$ -			\$ -		\$ -		
18					\$ -			\$ -		\$ -		
19					\$ -			\$ -		\$ -		
SUBTOTAL										\$ 12,600.00	\$ 136,804.03	
OH @ 10%										\$ 1,260.00	\$ -	
PROFIT @ 10%										\$ 1,260.00	\$ 13,680.40	
SUB TOTAL										\$ 15,120.00	\$ 150,484.43	
BOND & INSURANCE COST										\$ 378.00	\$ 3,762.11	
TOTAL										\$ 15,498.00	\$ 154,246.54	
GRAND TOTAL										\$	169,744.54	

1. The above proposal is valid as a lump sum and breakdown of individual task is for informational purposes only.

2. Equipment includes dump truck, dump fees, hauling costs, power tools such as saws, air compressors, safety equipment, hand tools, wheel barrows etc. (as applicable to the job).

3. Labor rates include labor burden including Worker's Comp. Ins, Other Ins., FICA, Unemployment etc.

4. EXCLUSIONS: SEE COVER LETTER

5. PRICE QUALIFICATION : Because of current supply chain challenges, most construction products are subject to delayed delivery times and unusual price volatility due to conditions that are beyond of the General Contractor. Currently, we are unable to procure any future price obligations from the various subcontractors and manufacturers. As a result, we are unable to offer any price protection for this job. The pricing presented are based upon current material costs, which are subject to change at any time. CONSYS, Inc is doing their best to mitigate these issues, but we can't be held responsible for the cost or material delivery impacts that are beyond our control. If there is an increase in the cost of the products between when the project is bid and when the work is performed, the amount of the contract may increase to reflect the additional costs being incurred. If product delivery issues or material increases occur, we will provide proper notification and documentation to support any claims submitted.

Contract Change Order Proposal



Date: May 24, 2024

COP#:

From: FieldTurf USA, Inc.
7445 Côte-de-Liesse Road, Suite 200
Montreal, Quebec H4T 1G2

To: CONSYS, Inc.
732 Kennedy St. NW
Washington, DC 20011

Project: UDC Soccer Lacrosse Field
4200 Connecticut Ave NW
Washington, DC 20008

Contact: Vijay Kasimsetty, Vice President
Phone: 202-545-1333

Ref: 88010310

Fax:
Email: vijay@consys-inc.net

Scope Description:

- Additional Cost of Site Work per Attached Spreadsheet
- OH&P 10%
- Additional installation cost due to initial budget dating back to December 2022.

DESCRIPTION	QTY	UNIT	UP	PRICE
Additional Site Work	1	EA	105565.20	\$105,565.20
FieldTurf OH&P	1	EA	10556.52	\$10,556.52
Additional Installation	1	LS	20682.31	\$20,682.31

TOTAL CHANGE ORDER: **\$136,804.03**

██████████	██████████
██████████	██████████
██████████	██████████

Notes/Exclusions:

- Quote is valid for thirty (30) calendar days
- The Contract Time will be increased by 0 days.

It is mutually agreed that for the above-referenced changes to take place, the original contract price will be adjusted by the above-referenced amount, which will become payable in accordance with the same terms and conditions as in the original contract or purchase order.

If all the terms of this change order are acceptable please have an authorized representative sign the bottom of this document and return it to FieldTurf's Montreal office, or as otherwise provided in the contract documents. FieldTurf will, in turn, provide a fully executed copy for your records. Once this document is fully executed, it will be considered a revision/modification to the original contract or purchase order.

FieldTurf USA, Inc.

Owner/General Contractor

Authorized Representative

Vijay Kasimsetty

Authorized Representative

Date

Date 05/24/24



CONTRACT NO.: GF-2020-C-0036

PROJECT NAME: UDC – Replace Natural Grass Athletic Field with Synthetic Turf

ATTACHMENT A -BCD 1 Back-up – ItemNo. 18

2502 Martin Luther King Junior Avenue, SE Washington, DC 20020
Office: (202) 545-1333; Fax: (202) 545-1339; e-mail: consys@consys-inc.net
www.consys-inc.net



August 15, 2024

VIA e-mail: eddie.whitaker@udc.edu
mgadson@udc.edu

Mr. Eddie Whitaker
Contracting Officer
The University of the District of Columbia
Office of Strategic Sourcing & Procurement
4200 Connecticut Avenue, NW
Building 39, Suite 200C
Washington, DC 20008

Re: Contract No. GF-2020-C-0036 – Replace Natural Grass Athletic Field with Synthetic Turf – PCR 35 - Chain Link Fence Posts & Panels

Mr. Whitaker:

Consys, Inc. hereby submits this PCR for having to complete the below mentioned work for a firm lump sum price of **\$3,777.13.**

SCOPE OF WORK:

- Change in fence fabric and gauge as per RFI 30 response
- Final clean-up of our area of work

We respectfully request you to review this PCR and issue us a necessary change order for this added work that has to be performed.

EXCLUSIONS:

- All permits and any utility deposit
- Excludes patching and repair of color concrete
- All structural support, roofing, architectural, mechanical, plumbing, sprinkler and FFE work
- All hazmat work

We, thank you once again for providing us the opportunity to submit this proposal. Our proposal is valid for a period of 30 days.

Consys, Inc. is a CBE & MDOT-MBE certified company.

If you need any further clarification, feel free to contact the undersigned at (202) 439-4123.

Sincerely,

Vijay R. Kasimsetty
Vice President

Cc: Alan Walsh, COTR and File

2502 Martin Luther King Junior Ave. SE Washington, DC 20020
Office: (202) 545-1333; Fax: (202) 545-1339; e-mail: consys@consys-inc.net
www.consys-inc.net

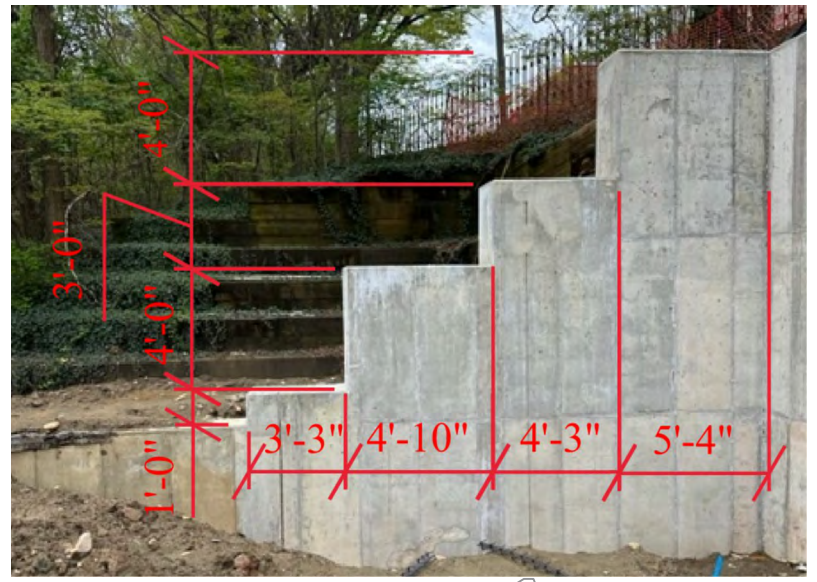

THIS PHOTO IS FLIPPED

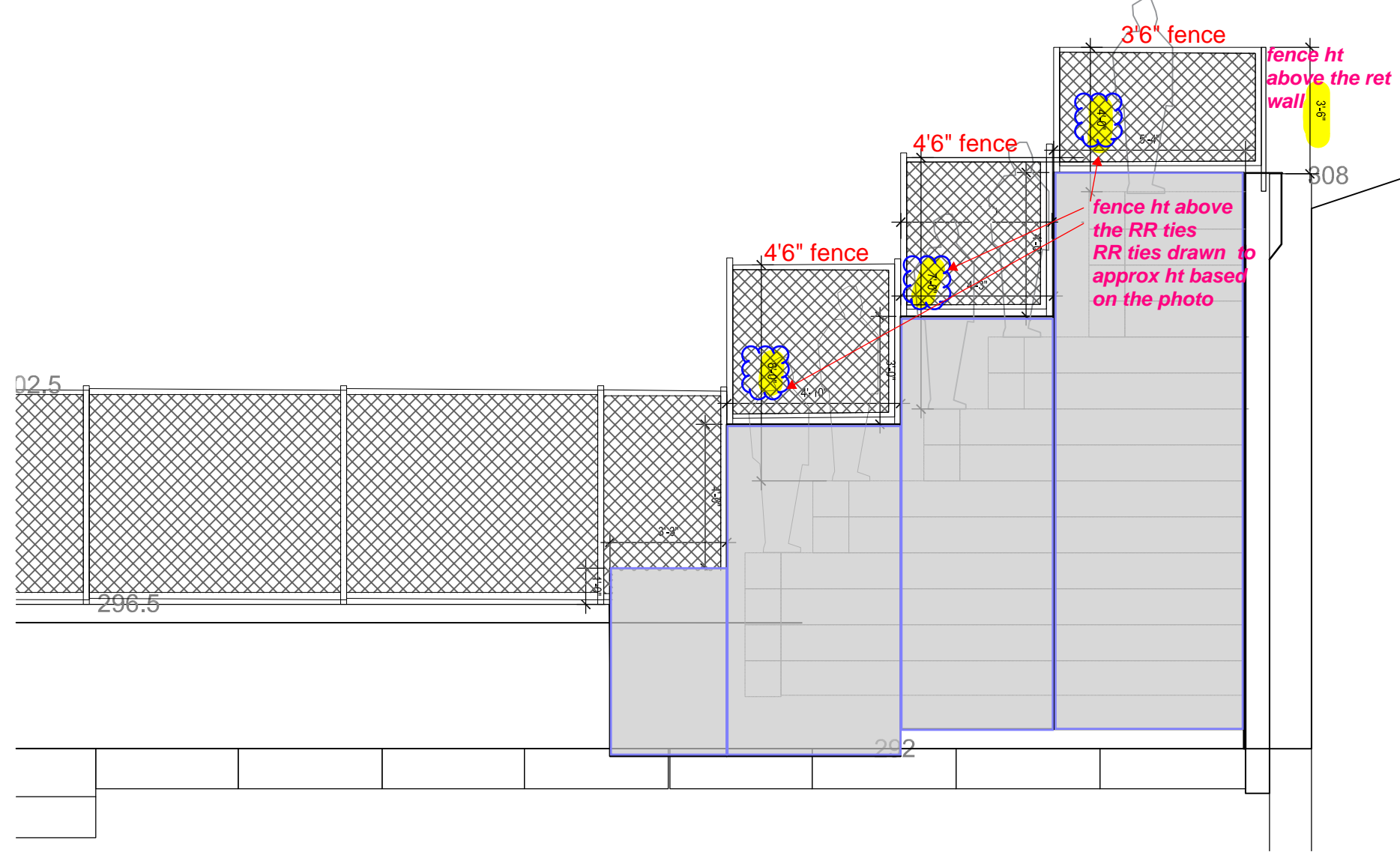
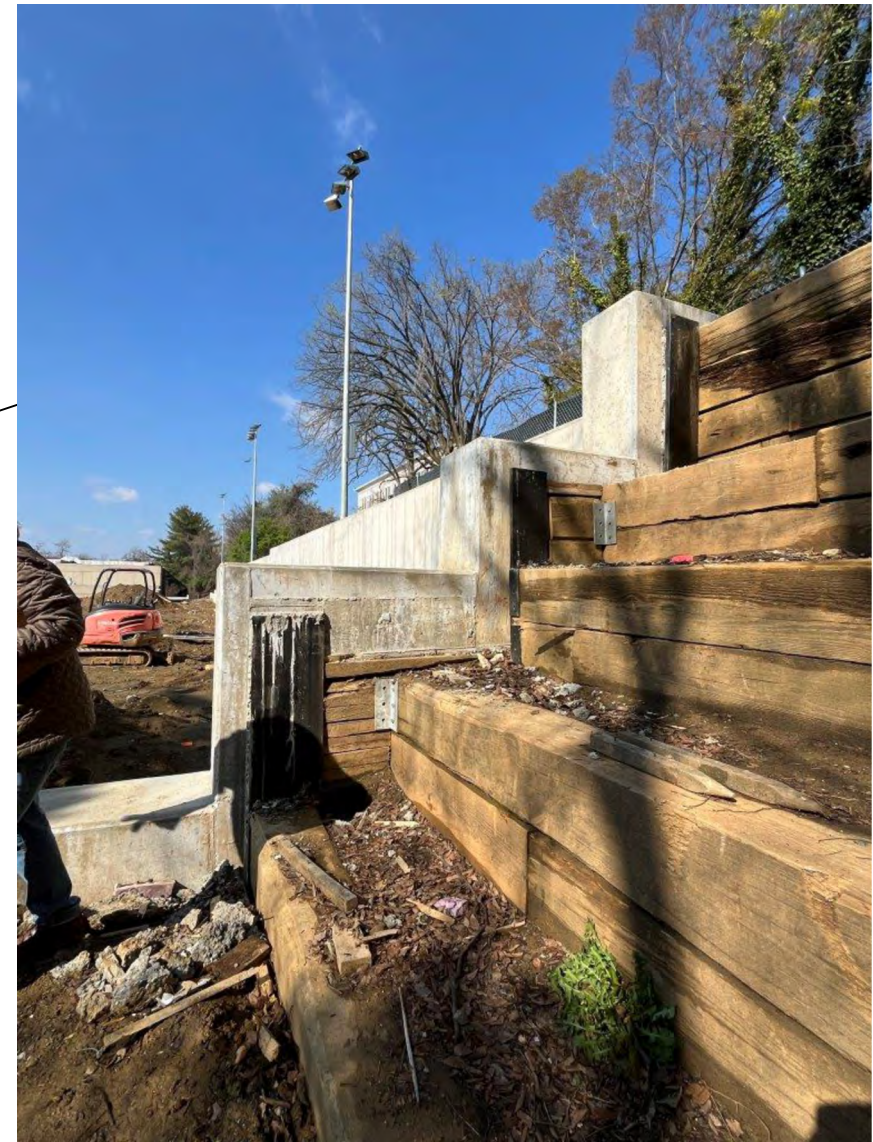

**UDC VN - SW CORNER - FENCE
24 0409**



Construction Estimate

Project: GF-2020-C-0036, RNgAFwST - PCR 35 - Chain Linke Fence Posts & Panels

Item No.	Description	Unit	Quantity	Material	Material Costs	Labor Rate	Hours	Labor Costs	Equipment	Line Total	Subcontractor	Remarks
1	Additional chain link panles and fence posts	Job	1		\$ -			\$ -		\$ -	\$3,350.00	See attached subcontractor inv
2					\$ -			\$ -		\$ -		
3					\$ -			\$ -		\$ -		
4					\$ -			\$ -		\$ -		
5					\$ -			\$ -		\$ -		
6					\$ -			\$ -		\$ -		
7					\$ -			\$ -		\$ -		
8					\$ -			\$ -		\$ -		
9					\$ -			\$ -		\$ -		
10					\$ -			\$ -		\$ -		
SUBTOTAL										\$ -	\$ 3,350.00	
OH @ 10%										\$ -	\$ -	
PROFIT @ 10%										\$ -	\$ 335.00	
SUB TOTAL										\$ -	\$ 3,685.00	
BOND & INSURANCE COST										\$ -	\$ 92.13	
TOTAL										\$ -	\$ 3,777.13	
GRAND TOTAL										\$	3,777.13	

1. The above proposal is valid as a lump sum and breakdown of individual task is for informational purposes only.

2. Equipment includes dump truck, dump fees, hauling costs, power tools such as saws, air compressors, safety equipment, hand tools, wheel barrows etc. (as applicable to the job).

3. Labor rates include labor burden including Worker's Comp. Ins., Other Ins., FICA, Unemployment etc.

4. EXCLUSIONS: SEE COVER LETTER

5. PRICE QUALIFICATION : Because of current supply chain challenges, most construction products are subject to delayed delivery times and unusual price volatility due to conditions that are beyond of the General Contractor. Currently, we are unable to procure any future price obligations from the various subcontractors and manufacturers. As a result, we are unable to offer any price protection for this job. The pricing presented are based upon current material costs, which are subject to change at any time. CONSYS, Inc is doing their best to mitigate these issues, but we can't be held responsible for the cost or material delivery impacts that are beyond our control. If there is an increase in the cost of the products between when the project is bid and when the work is performed, the amount of the contract may increase to reflect the additional costs being incurred. If product delivery issues or material increases occur, we will provide proper notification and documentation to support any claims submitted.

TJS FENCE LLC

Fence Division
905 S bruce st
tampa fl 33606

invoice

DATE:	8/2/24
INVOICE #	8224
Customer ID	0.000

Customer: CONSYS, Inc
732 Kennedy ST NW
Washington, DC
20011

DESCRIPTION	AMOUNT
Change orders on the UDC project which include - [REDACTED] - [REDACTED] - Add 3 additional stepped fence sections of 54" height \$2850.00 - Add 4 fence connections and 4 extra 3" post for stair landing \$1500.00	[REDACTED]

Contract Signatures

SUBTOTAL	\$ [REDACTED]
TAX RATE	0.000%
TAX	\$ -
TOTAL	\$ [REDACTED]

Make all checks payable to
TJS FENCE LLC AND
MAILED TO 905 S Bruce St
tampa fl 33606

If you have any questions about this invoice, please contact

Thank You For Your Business!



CONTRACT NO.: GF-2020-C-0036

PROJECT NAME: UDC – Replace Natural Grass Athletic Field with Synthetic Turf

ATTACHMENT A -BCD 1 Back-up – ItemNo. 19

2502 Martin Luther King Junior Avenue, SE Washington, DC 20020
Office: (202) 545-1333; Fax: (202) 545-1339; e-mail: consys@consys-inc.net
www.consys-inc.net



August 15, 2024

VIA e-mail: eddie.whitaker@udc.edu
mgadson@udc.edu

Mr. Eddie Whitaker
Contracting Officer
The University of the District of Columbia
Office of Strategic Sourcing & Procurement
4200 Connecticut Avenue, NW
Building 39, Suite 200C
Washington, DC 20008

Re: Contract No. GF-2020-C-0036 – Replace Natural Grass Athletic Field with Synthetic Turf – PCR 36 -
Additional Mesh Screens (ADA Ramp)

Mr. Whitaker:

Consys, Inc. hereby submits this PCR for having to complete the below mentioned work for a firm lump sum price of \$19,267.15.

SCOPE OF WORK:

- Furnish and install additional stainless steel mesh screen panels
- Final clean-up of our area of work

We respectfully request you to review this PCR and issue us a necessary change order for this added work that has to be performed.

EXCLUSIONS:

- All permits and any utility deposit
- All structural support, roofing, architectural, mechanical, plumbing, sprinkler and FFE work
- All hazmat work

We, thank you once again for providing us the opportunity to submit this proposal. Our proposal is valid for a period of 30 days.

Consys, Inc. is a CBE & MDOT-MBE certified company.

If you need any further clarification, feel free to contact the undersigned at (202) 439-4123.

Sincerely,

Vijay R. Kasimsetty
Vice President

Cc: Alan Walsh, COTR and File

2502 Martin Luther King Junior Ave. SE Washington, DC 20020
Office: (202) 545-1333; Fax: (202) 545-1339; e-mail: consys@consys-inc.net
www.consys-inc.net



Construction Estimate

Project: GF-2020-C-0036, RNgAFwST - PCR 36 - Additional Mesh Screens (ADA Ramp)

Item No.	Description	Unit	Quantity	Material	Material Costs	Labor Rate	Hours	Labor Costs	Equipment	Line Total	Subcontractor	Remarks
1	Additional Mesh Screen Panels (ADA Ramp)	Job	1	\$ 11,865.00	\$ 11,865.00	\$ 95.00	40	\$ 3,800.00		\$ 15,665.00		
2					\$ -			\$ -		\$ -		
3					\$ -			\$ -		\$ -		
4					\$ -			\$ -		\$ -		
5					\$ -			\$ -		\$ -		
6					\$ -			\$ -		\$ -		
7					\$ -			\$ -		\$ -		
8					\$ -			\$ -		\$ -		
9					\$ -			\$ -		\$ -		
10					\$ -			\$ -		\$ -		
SUBTOTAL										\$ 15,665.00	\$ -	
OH @ 10%										\$ 1,566.50	\$ -	
PROFIT @ 10%										\$ 1,566.50	\$ -	
SUB TOTAL										\$ 18,798.00	\$ -	
BOND & INSURANCE COST										\$ 469.95	\$ -	
TOTAL										\$ 19,267.95	\$ -	
GRAND TOTAL										\$	19,267.95	

1. The above proposal is valid as a lump sum and breakdown of individual task is for informational purposes only.

2. Equipment includes dump truck, dump fees, hauling costs, power tools such as saws, air compressors, safety equipment, hand tools, wheel barrows etc. (as applicable to the job).

3. Labor rates include labor burden including Worker's Comp. Ins., Other Ins., FICA, Unemployment etc.

4. EXCLUSIONS: SEE COVER LETTER

5. PRICE QUALIFICATION : Because of current supply chain challenges, most construction products are subject to delayed delivery times and unusual price volatility due to conditions that are beyond of the General Contractor. Currently, we are unable to procure any future price obligations from the various subcontractors and manufacturers. As a result, we are unable to offer any price protection for this job. The pricing presented are based upon current material costs, which are subject to change at any time. CONSYS, Inc is doing their best to mitigate these issues, but we can't be held responsible for the cost or material delivery impacts that are beyond our control. If there is an increase in the cost of the products between when the project is bid and when the work is performed, the amount of the contract may increase to reflect the additional costs being incurred. If product delivery issues or material increases occur, we will provide proper notification and documentation to support any claims submitted.



Change Order Request

Date: 11/8/24

COR #004

Submitted to: Vijay Kasimsetty
 Vice President
 Consys, Inc

Submitted by: Katie Thomas
 Project Manager
 Sightline Commercial Solutions

Project Name: UDC Van Ness Athletic Field North
 Subject: Added Mesh
 Reference:

Project No. 67525

Qty	UoM	Description	Unit Cost	Extended Price
1	LS	Added Mesh Panels	\$ 11,865.00	\$ 11,865.00

Total USD \$ 11,865.00

Original Contract Amount	\$	██████████
Net Change By Previous Change Orders	\$	██████████
Contract Sum Prior to this Change Order	\$	██████████
Contract Sum will be INCREASED By	\$	11,865.00
New Contract Sum Including This Change Order	\$	██████████

Currently we are:

- Not proceeding with this work, pending written acceptance
- Proceeding with this work, please acknowledge this change by signing below

Accepted By

Customer Name

Sightline Commercial Solutions

Signature

Signature

Printed Name

Katie Thomas
 Printed Name

Title

Project Manager
 Title

Date

11/8/2024
 Date



CONTRACT NO.: GF-2020-C-0036

PROJECT NAME: UDC – Replace Natural Grass Athletic Field with Synthetic Turf

ATTACHMENT A - BCD 1 Back-up – Item No. 20

2502 Martin Luther King Junior Avenue, SE Washington, DC 20020
Office: (202) 545-1333; Fax: (202) 545-1339; e-mail: consys@consys-inc.net
www.consys-inc.net



March 09, 2025

VIA e-mail: eddie.whitaker@udc.edu
mgadson@udc.edu

Mr. Eddie Whitaker
Contracting Officer
The University of the District of Columbia
Office of Strategic Sourcing & Procurement
4200 Connecticut Avenue, NW
Building 39, Suite 200C
Washington, DC 20008

Re: Contract No. GF-2020-C-0036 – Replace Natural Grass Athletic Field with Synthetic Turf – PCR 37 - Turf Grooming Equipment and Netting (REV 2)

Mr. Whitaker:

Consys, Inc. hereby submits this PCR for having to complete the below mentioned work for a firm lump sum price of **\$34,064.85.**

SCOPE OF WORK:

- Provide turf grooming equipment
- F & I Netting North Field Side and South Field Side on existing chain link fence. **Desing team to provide means of mounting.**
- Final clean-up of our area of work

We respectfully request you to review this PCR and issue us a necessary change order for this added work that has to be performed.

EXCLUSIONS:

- All permits and any utility deposit
- All mechanical, electrical, plumbing, sprinkler, architectural, FFE, access control and voice & data work
- All hazmat work

We, thank you once again for providing us the opportunity to submit this proposal. Our proposal is valid for a period of 30 days.

Consys, Inc. is a CBE & MDOT-MBE certified company.

If you need any further clarification, feel free to contact the undersigned at (202) 439-4123.

Sincerely,

Vijay R. Kasimsetty
Vice President

Cc: Joanna Edwards, Alan Walsh, COTR and File

2502 Martin Luther King Junior Avenue, SE Washington, DC 20020
Office: (202) 545-1333; Fax: (202) 545-1339; e-mail: consys@consys-inc.net
www.consys-inc.net



Construction Estimate

Project: GF-2020-C-0036, RNgAFwST - PCR 37 - Turf Grooming Equipment and Netting (REV - 2)

Item No.	Description	Unit	Quantity	Material	Material Costs	Labor Rate	Hours	Labor Costs	Equipment	Line Total	Subcontractor	Remarks
1	Turf Grooming Equipment	Job	1		\$ -			\$ -	\$ 16,295.00	\$ 16,295.00		
2	Equipment Netting	Job	1	\$ 5,000.00	\$ 5,000.00	\$ 65.00	60	\$ 3,900.00	\$ 2,500.00	\$ 11,400.00		In-house
3					\$ -			\$ -		\$ -		
4					\$ -			\$ -		\$ -		
5					\$ -			\$ -		\$ -		
6					\$ -			\$ -		\$ -		
7					\$ -			\$ -		\$ -		
8					\$ -			\$ -		\$ -		
9					\$ -			\$ -		\$ -		
10	Project Coordination	Job			\$ -			\$ -		\$ -		
11	Disposal of all trash	Job			\$ -			\$ -		\$ -		
12	Site clean-up	Job			\$ -			\$ -		\$ -		
13	Senior Project Manager	Hrs			\$ -			\$ -		\$ -		
14	Project Manager	Hrs			\$ -			\$ -		\$ -		
15	Project Superintendent	Hrs			\$ -			\$ -		\$ -		
16	Skilled Laborer	Hrs			\$ -			\$ -		\$ -		
17	Dumpster	Job			\$ -			\$ -		\$ -		
18					\$ -			\$ -		\$ -		
19					\$ -			\$ -		\$ -		
SUBTOTAL										\$ 27,695.00	\$ -	
OH @ 10%										\$ 2,769.50	\$ -	
PROFIT @ 10%										\$ 2,769.50	\$ -	
SUB TOTAL										\$ 33,234.00	\$ -	
BOND & INSURANCE COST										\$ 830.85	\$ -	
TOTAL										\$ 34,064.85	\$ -	
GRAND TOTAL										\$ 34,064.85		

1. The above proposal is valid as a lump sum and breakdown of individual task is for informational purposes only.

2. Equipment includes dump truck, dump fees, hauling costs, power tools such as saws, air compressors, safety equipment, hand tools, wheel barrows etc. (as applicable to the job).

3. Labor rates include labor burden including Worker's Comp. Ins., Other Ins., FICA, Unemployment etc.

4. EXCLUSIONS: SEE COVER LETTER

5. PRICE QUALIFICATION : Because of current supply chain challenges, most construction products are subject to delayed delivery times and unusual price volatility due to conditions that are beyond of the General Contractor. Currently, we are unable to procure any future price obligations from the various subcontractors and manufacturers. As a result, we are unable to offer any price protection for this job. The pricing presented are based upon current material costs, which are subject to change at any time. CONSYS, Inc is doing their best to mitigate these issues, but we can't be held responsible for the cost or material delivery impacts that are beyond our control. If there is an increase in the cost of the products between when the project is bid and when the work is performed, the amount of the contract may increase to reflect the additional costs being incurred. If product delivery issues or material increases occur, we will provide proper notification and documentation to support any claims submitted.

Quote Summary

Prepared For:
Field Turf, Inc
DC

Prepared By:
Josh Berman
Finch Turf, Inc.
9 Venture Way
Eldersburg, MD 21784
Phone: 800-783-3373
Mobile: 410-259-6433
jberman@finchturf.com

Quote Id: 32260978
Created On: 27 January 2025
Last Modified On: 28 January 2025
Expiration Date: 31 March 2025

Equipment Summary	Selling Price	Qty	Extended
JOHN DEERE GATOR™TX Turf (Model Year 2025)	\$ 16,295.00 X	1 =	\$ 16,295.00
Equipment Total			\$ 16,295.00

Quote Summary

Equipment Total	\$ 16,295.00
SubTotal	\$ 16,295.00
Est. Service Agreement Tax	\$ 0.00
Total	\$ 16,295.00
Down Payment	(0.00)
Rental Applied	(0.00)
Balance Due	\$ 16,295.00

Salesperson : X _____

Accepted By : X _____



Quote

Anthem Sports, LLC
2 Extrusion Drive

Phone	Fax
800-688-6709	860-599-8448
www.anthem-sports.com	

Date	Quote #
3/4/25	85508

Quote for:
Consys Inc Vijay Kasimsetty 2502 Martin Luther King Jr. Ave SE Washington DC 20020

Ship To
University of the District of Columbia Vijay Kasimsetty Recieving Dept 4200 Connecticut Ave, NW Bldg 38 Washington, DC 20008 US 202-439-8123

P.O. No.	Terms	Qt. CSR
	Pre Pay	CS

Anthem Part #	Description	Qty	U/M	Price	Total
A12-203 1	Kwik Goal Multi-Sport Backstop Replacement Net, 20'x80' Shipping & Handling Sales Tax	6	ea	669.95 158.43 0.00	4,019.70T 158.43T 0.00
PLUS MISCELLANEOUS INSTALLATION MATERIALS				\$821.87.	

Total	\$4,178.13
--------------	-------------------

**Quote is valid for 30 days unless otherwise specified.
Our manufactures are increasing prices regularly.**

**Due to supply chain delays estimated lead times
are also subject to change.**

Return Policy: You may return any new or unused items in original packaging for a refund within 30 days.
Email info@anthem-sports.com or visit www.anthem-sports.com/EasyReturns for details and exclusions.



CONTRACT NO.: GF-2020-C-0036

PROJECT NAME: UDC – Replace Natural Grass Athletic Field with Synthetic Turf

ATTACHMENT A - BCD 1 Back-up – Item No. 21

2502 Martin Luther King Junior Avenue, SE Washington, DC 20020
Office: (202) 545-1333; Fax: (202) 545-1339; e-mail: consys@consys-inc.net
www.consys-inc.net



February 2, 2025

VIA e-mail: eddie.whitaker@udc.edu
mgadson@udc.edu

Mr. Eddie Whitaker
Contracting Officer
The University of the District of Columbia
Office of Strategic Sourcing & Procurement
4200 Connecticut Avenue, NW
Building 39, Suite 200C
Washington, DC 20008

Re: Contract No. GF-2020-C-0036 – Replace Natural Grass Athletic Field with Synthetic Turf – PCR 38 -
Field Signage

Mr. Whitaker:

Consys, Inc. hereby submits this PCR for having to complete the below mentioned work for a firm lump sum price of **\$3,493.68**

SCOPE OF WORK:

- Provide and Install Field Safety / Operations Signage
- Final clean-up of our area of work

We respectfully request you to review this PCR and issue us a necessary change order for this added work that has to be performed.

EXCLUSIONS:

- All permits and any utility deposit
- All mechanical, electrical, plumbing, sprinkler, architectural, FFE, access control and voice & data work
- All hazmat work

We, thank you once again for providing us the opportunity to submit this proposal. Our proposal is valid for a period of 30 days.

Consys, Inc. is a CBE & MDOT-MBE certified company.

If you need any further clarification, feel free to contact the undersigned at (202) 439-4123.

Sincerely,

Vijay R. Kasimsetty
Vice President

Cc: Joanna Edwards, Alan Walsh, COTR and File

2502 Martin Luther King Junior Avenue, SE Washington, DC 20020
Office: (202) 545-1333; Fax: (202) 545-1339; e-mail: consys@consys-inc.net
www.consys-inc.net



Construction Estimate

Project: GF-2020-C-0036, RNgAFwST - PCR 38 - Field Signage

Item No.	Description	Unit	Quantity	Material	Material Costs	Labor Rate	Hours	Labor Costs	Equipment	Line Total	Subcontractor	Remarks
1	Field Signage	Job	1	\$ 2,400.39	\$ 2,400.39	\$ 55.00	8	\$ 440.00		\$ 2,840.39		
2					\$ -			\$ -		\$ -		
3					\$ -			\$ -		\$ -		
4					\$ -			\$ -		\$ -		
5					\$ -			\$ -		\$ -		
6					\$ -			\$ -		\$ -		
7					\$ -			\$ -		\$ -		
8					\$ -			\$ -		\$ -		
9					\$ -			\$ -		\$ -		
10	Project Coordination	Job			\$ -			\$ -		\$ -		
11	Disposal of all trash	Job			\$ -			\$ -		\$ -		
12	Site clean-up	Job			\$ -			\$ -		\$ -		
13	Senior Project Manager	Hrs			\$ -			\$ -		\$ -		
14	Project Manager	Hrs			\$ -			\$ -		\$ -		
15	Project Superintendent	Hrs			\$ -			\$ -		\$ -		
16	Skilled Laborer	Hrs			\$ -			\$ -		\$ -		
17	Dumpster	Job			\$ -			\$ -		\$ -		
18					\$ -			\$ -		\$ -		
19					\$ -			\$ -		\$ -		
SUBTOTAL										\$ 2,840.39	\$ -	
OH @ 10%										\$ 284.04	\$ -	
PROFIT @ 10%										\$ 284.04	\$ -	
SUB TOTAL										\$ 3,408.47	\$ -	
BOND & INSURANCE COST										\$ 85.21	\$ -	
TOTAL										\$ 3,493.68	\$ -	
GRAND TOTAL										\$	3,493.68	

1. The above proposal is valid as a lump sum and breakdown of individual task is for informational purposes only.

2. Equipment includes dump truck, dump fees, hauling costs, power tools such as saws, air compressors, safety equipment, hand tools, wheel barrows etc. (as applicable to the job).

3. Labor rates include labor burden including Worker's Comp. Ins, Other Ins., FICA, Unemployment etc.

4. EXCLUSIONS: SEE COVER LETTER

5. PRICE QUALIFICATION : Because of current supply chain challenges, most construction products are subject to delayed delivery times and unusual price volatility due to conditions that are beyond of the General Contractor. Currently, we are unable to procure any future price obligations from the various subcontractors and manufacturers. As a result, we are unable to offer any price protection for this job. The pricing presented are based upon current material costs, which are subject to change at any time. CONSYS, Inc is doing their best to mitigate these issues, but we can't be held responsible for the cost or material delivery impacts that are beyond our control. If there is an increase in the cost of the products between when the project is bid and when the work is performed, the amount of the contract may increase to reflect the additional costs being incurred. If product delivery issues or material increases occur, we will provide proper notification and documentation to support any claims submitted.



4131 Howard Avenue
Kensington, MD 20895
(301) 589-3305

INVOICE

I-SS-35508

www.image360dcss.com

Completed Date: 9/9/2024

Payment Terms: Net 45

Payment Due Date: 10/24/2024

Created Date: 8/29/2024

DESCRIPTION: UDC Field Rule Signs

Bill To: Consys, Inc
PO Box 60825
Washington, DC 20039
US

Pickup At: Image360 - DC-Silver Spring
4131 Howard Avenue
Kensington, MD 20895
US

Ordered By: Vijay Kasimsetty
Email: vijay@consys-inc.net
Work Phone: (202) 545-1333
Cell Phone: (202) 439-4123

Salesperson: Andrew Akers
Entered By: Andrew Akers

NO.	Product Summary	QTY	UNIT PRICE	AMOUNT
1	Field Rule Signs	5	\$465.078	\$2,325.39
1.1	.080" Aluminum - Part Qty: 1 Width: 36.00" Height: 35.00"			
	Round Corners - Rounded Corners Lamination - Lamination Type: Cast Lamine Matte			
1.2	Production Assembly - Part Qty: 1			
1.3	Linklip Chainlink Fence Mount - Part Qty: 10			
2	Graphics and Pre Production	1	\$75.00	\$75.00
2.1	Set Up - Part Qty: 1			

Subtotal:	\$2,400.39
Taxes:	\$0.00
Grand Total:	\$2,400.39
Amount Paid:	\$0.00
BALANCE DUE:	\$2,400.39

Signature: _____ **Date:** _____



CONTRACT NO.: GF-2020-C-0036

PROJECT NAME: UDC – Replace Natural Grass Athletic Field with Synthetic Turf

ATTACHMENT A - BCD 1 Back-up – Item No. 22

2502 Martin Luther King Junior Avenue, SE Washington, DC 20020
Office: (202) 545-1333; Fax: (202) 545-1339; e-mail: consys@consys-inc.net
www.consys-inc.net



July 20, 2024

VIA e-mail: eddie.whitaker@udc.edu
mgadson@udc.edu

Mr. Eddie Whitaker
Contracting Officer
The University of the District of Columbia
Office of Strategic Sourcing & Procurement
4200 Connecticut Avenue, NW
Building 39, Suite 200C
Washington, DC 20008

Re: Contract No. GF-2020-C-0036 – Replace Natural Grass Athletic Field with Synthetic Turf – PCR 39 - Shelter Wheel Kit

Mr. Whitaker:

Consys, Inc. hereby submits this PCR for having to complete the below mentioned work for a firm lump sum price of **\$3,657.04.**

SCOPE OF WORK:

- Furnish canopy shelter wheel kit
- Final clean-up of our area of work

We respectfully request you to review this PCR and issue us a necessary change order for this added work that has to be performed.

EXCLUSIONS:

- All permits and any utility deposit
- All mechanical, electrical, plumbing, sprinkler, architectural, FFE, access control and voice & data work
- All hazmat work

We, thank you once again for providing us the opportunity to submit this proposal. Our proposal is valid for a period of 30 days.

Consys, Inc. is a CBE & MDOT-MBE certified company.

If you need any further clarification, feel free to contact the undersigned at (202) 439-4123.

Sincerely,

Vijay R. Kasimsetty
Vice President

Cc: Joanna Edwards, Alan Walsh, COTR and File

2502 Martin Luther King Junior Avenue, SE Washington, DC 20020
Office: (202) 545-1333; Fax: (202) 545-1339; e-mail: consys@consys-inc.net
www.consys-inc.net



Construction Estimate

Project: GF-2020-C-0036, RNgAFwST - PCR 39 - Shelter Wheel Kit

Item No.	Description	Unit	Quantity	Material	Material Costs	Labor Rate	Hours	Labor Costs	Equipment	Line Total	Subcontractor	Remarks
1	Shelter Wheel Kit	Job	1	\$ 2,973.20	\$ 2,973.20			\$ -		\$ 2,973.20		
2					\$ -			\$ -		\$ -		
3					\$ -			\$ -		\$ -		
4					\$ -			\$ -		\$ -		
5					\$ -			\$ -		\$ -		
6					\$ -			\$ -		\$ -		
7					\$ -			\$ -		\$ -		
8					\$ -			\$ -		\$ -		
9					\$ -			\$ -		\$ -		
10	Project Coordination	Job			\$ -			\$ -		\$ -		
11	Disposal of all trash	Job			\$ -			\$ -		\$ -		
12	Site clean-up	Job			\$ -			\$ -		\$ -		
13	Senior Project Manager	Hrs			\$ -			\$ -		\$ -		
14	Project Manager	Hrs			\$ -			\$ -		\$ -		
15	Project Superintendent	Hrs			\$ -			\$ -		\$ -		
16	Skilled Laborer	Hrs			\$ -			\$ -		\$ -		
17	Dumpster	Job			\$ -			\$ -		\$ -		
18					\$ -			\$ -		\$ -		
19					\$ -			\$ -		\$ -		
SUBTOTAL										\$ 2,973.20	\$ -	
OH @ 10%										\$ 297.32	\$ -	
PROFIT @ 10%										\$ 297.32	\$ -	
SUB TOTAL										\$ 3,567.84	\$ -	
BOND & INSURANCE COST										\$ 89.20	\$ -	
TOTAL										\$ 3,657.04	\$ -	
GRAND TOTAL										\$	3,657.04	

1. The above proposal is valid as a lump sum and breakdown of individual task is for informational purposes only.

2. Equipment includes dump truck, dump fees, hauling costs, power tools such as saws, air compressors, safety equipment, hand tools, wheel barrows etc. (as applicable to the job).

3. Labor rates include labor burden including Worker's Comp. Ins, Other Ins., FICA, Unemployment etc.

4. EXCLUSIONS: SEE COVER LETTER

5. PRICE QUALIFICATION : Because of current supply chain challenges, most construction products are subject to delayed delivery times and unusual price volatility due to conditions that are beyond of the General Contractor. Currently, we are unable to procure any future price obligations from the various subcontractors and manufacturers. As a result, we are unable to offer any price protection for this job. The pricing presented are based upon current material costs, which are subject to change at any time. CONSYS, Inc is doing their best to mitigate these issues, but we can't be held responsible for the cost or material delivery impacts that are beyond our control. If there is an increase in the cost of the products between when the project is bid and when the work is performed, the amount of the contract may increase to reflect the additional costs being incurred. If product delivery issues or material increases occur, we will provide proper notification and documentation to support any claims submitted.



[Home](#) / [Cart](#)

[← CONTINUE SHOPPING](#)

PROCEED TO CHECKOUT

- OR -



USE YOUR AMAZON ACCOUNT



Product

Price

Qty

Subtotal Actions



Product	Price	Qty	Subtotal	Actions
 <p><u>Kwik Goal Shelter Wheel Kit</u> SKU: A07-767</p> <p><u>REMOVE</u> Typically ships in 3-4 business days</p> <p>\$1,425.00</p> <p>- <input type="text" value="2"/> +</p> <p><u>EDIT</u></p>				
			\$2,850.00	<u>Edit</u> <u>REMOVE</u> ✕

[← CONTINUE SHOPPING](#)

[↻ UPDATE CART](#)

PROCEED TO CHECKOUT

- OR -

Pay with  **>>**

USE YOUR AMAZON ACCOUNT

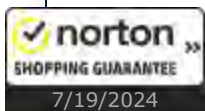

Subtotal	\$2,850.00
Shipping & Handling (Standard Shipping) 48 contiguous United States	\$123.20
GRAND TOTAL:	\$2,973.20



Tax Exempt Organizations: Before ordering, [click here](#) for instructions.

PLEASE NOTE: Ship dates and product availability may change due to supply chain delays with many manufacturers. We will notify you of any changes to your order.

Items marked "In Stock" ship same day if ordered by 2pm EST (M-F). [Click here for Transit Times.](#)

Items marked "Typically Ships" ship directly from the manufacturer. Allow 2-5 business days for transit beyond the estimated ship date for these items to arrive. [Click here for details.](#)

Express Shipments: Call Anthem Sports for pricing or request a quote in the comments section when you checkout. Please include your need-by date.

Shipping Disclaimer: Online orders will ship only to the 48 contiguous United States. At this time shipping is not available to international and APO/FPO addresses. All orders shipping to AK or HI require the addition of freight cost and approval before shipping. For these locations and for Freight Items (item page will note "Freight Quote Required") you may use the "Move Cart to My Quote" feature to obtain a quote before ordering.

Easy Returns: Order with confidence. [Click here for details.](#)

Coupon Code



YOU ALSO VIEWED



\$1,425.00

Kwik Goal Shelter Wheel Kit

 [Move Cart to My Quote](#)

SHOPPING CART

 Trustpilot



TrustScore 4.8
3,435 reviews



Anthem Sports © 2024 All Rights Reserved





CONTRACT NO.: GF-2020-C-0036

PROJECT NAME: UDC – Replace Natural Grass Athletic Field with Synthetic Turf

ATTACHMENT A - BCD 1 Back-up – Item No. 23

2502 Martin Luther King Junior Avenue, SE Washington, DC 20020
Office: (202) 545-1333; Fax: (202) 545-1339; e-mail: consys@consys-inc.net
www.consys-inc.net



March 09, 2025

VIA e-mail: eddie.whitaker@udc.edu
mgadson@udc.edu

Mr. Eddie Whitaker
Contracting Officer
The University of the District of Columbia
Office of Strategic Sourcing & Procurement
4200 Connecticut Avenue, NW
Building 39, Suite 200C
Washington, DC 20008

Re: Contract No. GF-2020-C-0036 – Replace Natural Grass Athletic Field with Synthetic Turf – PCR 41 -
Additional Wall Padding (South Wall)

Mr. Whitaker:

Consys, Inc. hereby submits this PCR for having to complete the below mentioned work for a firm lump
sum price of \$37,631.84.

SCOPE OF WORK:

- F & I wall padding on the south field side
- Final clean-up of our area of work

We respectfully request you to review this PCR and issue us a necessary change order for this added work
that has to be performed.

EXCLUSIONS:

- All permits and any utility deposit
- All mechanical, electrical, plumbing, sprinkler, architectural, FFE, access control and voice & data
work
- All hazmat work

We, thank you once again for providing us the opportunity to submit this proposal. Our proposal is valid for
a period of 30 days.

Consys, Inc. is a CBE & MDOT-MBE certified company.

If you need any further clarification, feel free to contact the undersigned at (202) 439-4123.

Sincerely,

Vijay R. Kasimsetty
Vice President

Cc: Joanna Edwards, Alan Walsh, COTR and File

2502 Martin Luther King Junior Avenue, SE Washington, DC 20020
Office: (202) 545-1333; Fax: (202) 545-1339; e-mail: consys@consys-inc.net
www.consys-inc.net



Construction Estimate

Project: GF-2020-C-0036, RNGAFwST - PCR 41 - Additional Wall Padding (South Wall)

Item No.	Description	Unit	Quantity	Material	Material Costs	Labor Rate	Hours	Labor Costs	Equipment	Line Total	Subcontractor	Remarks
1	Wall Padding (South Wall)	Job	1	\$ 25,395.00	\$ 25,395.00	\$ 65.00	80	\$ 5,200.00		\$ 30,595.00		In-house
2					\$ -			\$ -		\$ -		
3					\$ -			\$ -		\$ -		
4					\$ -			\$ -		\$ -		
5					\$ -			\$ -		\$ -		
6					\$ -			\$ -		\$ -		
7					\$ -			\$ -		\$ -		
8					\$ -			\$ -		\$ -		
9					\$ -			\$ -		\$ -		
10	Project Coordination	Job			\$ -			\$ -		\$ -		
11	Disposal of all trash	Job			\$ -			\$ -		\$ -		
12	Site clean-up	Job			\$ -			\$ -		\$ -		
13	Senior Project Manager	Hrs			\$ -			\$ -		\$ -		
14	Project Manager	Hrs			\$ -			\$ -		\$ -		
15	Project Superintendent	Hrs			\$ -			\$ -		\$ -		
16	Skilled Laborer	Hrs			\$ -			\$ -		\$ -		
17	Dumpster	Job			\$ -			\$ -		\$ -		
18					\$ -			\$ -		\$ -		
19					\$ -			\$ -		\$ -		
SUBTOTAL										\$ 30,595.00	\$ -	
OH @ 10%										\$ 3,059.50	\$ -	
PROFIT @ 10%										\$ 3,059.50	\$ -	
SUB TOTAL										\$ 36,714.00	\$ -	
BOND & INSURANCE COST										\$ 917.84	\$ -	
TOTAL										\$ 37,631.84	\$ -	
GRAND TOTAL										\$ 37,631.84		

1. The above proposal is valid as a lump sum and breakdown of individual task is for informational purposes only.

2. Equipment includes dump truck, dump fees, hauling costs, power tools such as saws, air compressors, safety equipment, hand tools, wheel barrows etc. (as applicable to the job).

3. Labor rates include labor burden including Worker's Comp. Ins., Other Ins., FICA, Unemployment etc.

4. EXCLUSIONS: SEE COVER LETTER

5. PRICE QUALIFICATION : Because of current supply chain challenges, most construction products are subject to delayed delivery times and unusual price volatility due to conditions that are beyond of the General Contractor. Currently, we are unable to procure any future price obligations from the various subcontractors and manufacturers. As a result, we are unable to offer any price protection for this job. The pricing presented are based upon current material costs, which are subject to change at any time. CONSYS, Inc is doing their best to mitigate these issues, but we can't be held responsible for the cost or material delivery impacts that are beyond our control. If there is an increase in the cost of the products between when the project is bid and when the work is performed, the amount of the contract may increase to reflect the additional costs being incurred. If product delivery issues or material increases occur, we will provide proper notification and documentation to support any claims submitted.



Remit To:
Sportsfield Specialties
PO Box 231
Delhi, NY 13753

Quote Number: 113044

QUOTE

Page: 1 of 3

<p>Quote To: Consys, Inc. 2502 Martin Luther King Jr. Ave, SEWashington DC 20020US</p>	<p>Ship To: University of D.C. 4200 Connecticut Ave, NW Building 38 Receiving Washington, DC 20008 US</p>	<p>Date: 3/4/2025 Expires: 5/3/2025 PO Num: UDC Additional Padding Sales Person: Jake Newkerk Cell: 607-437-3594 Email: jnewkerk@sportsfield.com</p>
---	--	---

USD

Line	Part	Description	Qty /	Sales UoM	Unit Price	Line Total
1	PFWPZ44		57.00	EA	\$365.00	\$20,805.00

ProZone® Premium Field Wall Pad - Size: 4'W x 4'H x 3-3/4"D, High Performance 3" HDPU Foam, 19 oz. UV Resistant Premium Outdoor Vinyl Covering, 3/4" Moisture Resistant Composite Backing, Aluminum Z-Clip Wall Mounting System, 3-Year Manufacturer's Product Warranty, Independently Tested Impact Performance

QUOTE - Miscellaneous Charge -	
Description	Ext. Price
1.) Freight-NC-Construction	\$2,250.00

Lines Total	\$20,805.00
Total Taxes	\$0.00
Line Miscellaneous	\$0.00
Quote Miscellaneous	\$2,250.00
Quote Total	\$23,055.00

CONCRETE WALL ANCHORS \$2,340.00



Remit To:
Sportsfield Specialties
PO Box 231
Delhi, NY 13753

Quote Number: 113044

QUOTE

Page: 2 of 3

1. Customer is responsible for material take-off, quantities and specification compliance and/or equivalency of quoted products.
2. All prices listed are in US Dollars
3. Lead times vary by product and begin after receipt of purchase order, credit approval, and acceptance of color, material(s) and design. Please reach out to your team at Sportsfield Specialties for specific product lead times.
4. All freight is FOB Origin. **Freight rates are estimates provided at the time of quotation. Actual freight rates, include shipping & handling, will be billed at the time of shipment. The customer is responsible for any difference between the quoted freight rate and the actual freight rate at the time of shipment.** The actual freight rates may differ from the estimates as a result of variable factors, such as the change in product quantity and/or material order, state of national economy, fuel costs, capacity and/or rate levels at the time of shipment. Split orders will require additional freight charges. Freight quoted does not include additional equipment to unload or unloading services, assembly or installation.
5. Applicable State and Local Sales Tax will be added to the final invoice unless a tax exempt or Resale Certificate is provided prior to order shipment.
6. Wire transfers, by check and established credit terms are accepted payment methods. Accepted credit cards are VISA, Mastercard and American Express.
7. Pricing assumes any electrical connections and wiring are supplied by others unless otherwise indicated.
8. Customer is responsible for approval and associated cost of any applicable local and state codes.
9. Due to the increase of steel and aluminum raw material pricing caused by increased demand, coupled with market instability and uncertainty due to the implementation of international trade tariffs, Sportsfield Specialties, Inc. will no longer be able to guarantee current product pricing after this quotation has expired in sixty (60) days. To avoid a potential product price increase, customers will need to provide Sportsfield Specialties, Inc. with a fully executed purchase order or letter of intent before this quotation expires to guarantee this product pricing. Sportsfield Specialties, Inc reserves the right to requote product pricing as necessary based on current steel and aluminum raw material pricing once this quotation has expired in sixty (60) days.
10. If your quote includes custom and/or make-to-order item(s), the item(s) will not be fully released into production until all order information is verified. This information includes color choices, bench configurations, field dimensions and any necessary engineering. Custom items and items with digital graphics require a signed rendering prior to release into production. Once color selections are made and material has been ordered for custom or make-to-order items, the order cannot be canceled. Custom and make-to-order items cannot be returned.



Remit To:
Sportsfield Specialties
PO Box 231
Delhi, NY 13753

Quote Number: 113044

QUOTE

Page: 3 of 3

Date

Signature

Printed Name/Title

OCP Request for Proposal (BCD 001)

Mary Ann Harris, MPA
Director

December 4, 2024

Mr. Vijay Kasimsetty
Consys, Inc.
732 Kennedy Street, N.W.
Washington, DC 20011

Contract Number: GF-2020-C-0036_BCD 001
Solicitation Number: GF-2020-B-0036
Subject: Replacement of the Natural Grass Athletic Field Synthetic Turf

Dear Mr. Kasimsetty:

Immediately upon receipt of this document and in accordance with Article 1 or 3 of the contract, you are directed to proceed with the enclosed Statement of Work.

If a request for an increase in contract amount or time is to be made, or if a credit is due to the District of Columbia, your written request or statement of credit should be promptly made to the Contracting Officer.

Your request for an increase or statement of credit should include details on labor cost, material, equipment, overhead, profit, and any pertinent data that affect the subject change. Should an extension of the contract performance period be a consideration, a complete justification is also required, explaining the time involved and how this change affects the contract. You should also describe the activity or activities affected and the number of days each activity(s) duration must be increased or decreased. However, all items of work not affected by this change shall be completed within the time specified in the contract.

Please submit your complete proposal within seven (7) days from receipt of this letter.

Sincerely,

Eddie M. Whitaker

Eddie Whitaker
Contracting Officer

Scope of Work

Subject: BCD No. 001 (Article 3)
Contract No.: GF-2020-C-0036
Replace Natural Grass Athletic Field with Synthetic Turf Project

The contractor shall proceed with the below scope of work with all Work in compliance with base contract requirements.

Description of Change

Bid Drawings to Permit Drawings - Changes:

1) Additional Erosion & Soil Control Changes

Contractor to furnish and install additional ESC changes as defined in the Permit drawing set.

2) Field Drainage Drawings

Contractor to install under-turf drainage as defined in the Permit drawing set.

Geothermal Pipe Work:

1) Exiting Pipes Relocation

Contractor to retrench and sink or replace existing pipes in the SE field area that are too close to the finished field surface elevation

2) Sand Bedding in Pipe Trenches

Contractor to provide sand bedding in new trenches to support the geothermal pipes, per original project spec. for the New Student Center project.

Removal of Existing Earthwork & Unsuitable Soils:

1) Buried Infrastructure Removal & Disposal

Contractor to excavate abandoned buried concrete infrastructure and utilities elements encountered during the field grading process. Elements to be loaded up and hauled off.

2) Unusable Soils Cutting & Removal

Contractor to cut existing soils in areas that are pumping up ground water and replace with suitable soils and compact to specified grade. Soils to be removed from the site.

DOEE Requirements:

1) Soil Stabilization

Per inspector Peter Nwangwu of DOEE, soils must be stabilized by grass before he will close out the ESC portion of the construction permit. Provide seed and straw to the area immediately behind the west retaining wall. Provide soil and sod at disrupted areas outside the field – north wall exterior, ADA ramp hill area, south wall exterior.

South Athletic Field - Equipment and Materials Lay-down Area Modifications for Use:

1) Silt Fence & Stone Drive

Contractor to install silt fence at the Van Ness construction site entry. A temporary stone drive will be installed. The stone will be removed, and grass restored at the end of the project.

2) UDC/OPSEM – Chain Link Fence Along Van Ness

Contractor to install fence at the direction of UDC’s OPSEM to deter the public from parking in the field.

3) Storage

Contractor to provide storage for field grooming equipment and turf rolls.

Fencing:

1) Mesh & Gauge Increase

RFI 30’s A/E response clarifies a discrepancy between the drawings and specs regarding the sizing of the fence mesh sizing and gauge – contractor to provide larger sizes per RFI response.

2) Additional Fence Panels at SW Corner

Contractor to provide additional fence panels where the new SW retaining wall meets the existing lagging to eliminate unauthorized access to the field.

Water Availability for Fans/Players & Turf:

Yard Hydrant and Bottle Filling/Water Fountain Station

- 1) Contractor to provide water supply from Bldg. 46W to wall mounted bottle-filler water fountain and concrete pad underneath.

Contractor to provide a waterline across the field from Bldg. 46W to a lawn hydrant in the SW end of the field, outside the playing field to allow watering of the field to reduce the heat on the turf.

ADA & Emergency Vehicle Access Related:

Concrete & Railings

- 1) The Emergency Vehicle Access designed for the northwest corner of the field was not feasible due to the steep grade at the west property line. Contractor to add stairs, railings, and drainage so Athletics staff can safely access the field from the Sports Complex.

A new emergency vehicle access will be created at the SE end of the field. Contractor to grade area connecting to the Van Ness service road and provide a concrete pad at the field entrance.

- 2) The ADA ramp requires 2 new walls, railings and panels since the existing drawings did not have the correct elevations for the south and east walls on the lowest ramps. Walls will require excavation, installation of drainboard and a French drain to alleviate hydrostatic pressure. Contractor to install.

Turf Changes:

Increase in Turf Area & Turf Price

- 1) The actual field area was larger than design measurement and costs increased at the point this was ordered.
- 2) Athletics needs 2 sets of wheels and dollies to move covered benches on and off the field for different sports.

Certificate of Insurance



CERTIFICATE OF LIABILITY INSURANCE

DATE (MM/DD/YYYY)

11/06/2024

THIS CERTIFICATE IS ISSUED AS A MATTER OF INFORMATION ONLY AND CONFERS NO RIGHTS UPON THE CERTIFICATE HOLDER. THIS CERTIFICATE DOES NOT AFFIRMATIVELY OR NEGATIVELY AMEND, EXTEND OR ALTER THE COVERAGE AFFORDED BY THE POLICIES BELOW. THIS CERTIFICATE OF INSURANCE DOES NOT CONSTITUTE A CONTRACT BETWEEN THE ISSUING INSURER(S), AUTHORIZED REPRESENTATIVE OR PRODUCER, AND THE CERTIFICATE HOLDER.

IMPORTANT: If the certificate holder is an ADDITIONAL INSURED, the policy(ies) must have ADDITIONAL INSURED provisions or be endorsed. If SUBROGATION IS WAIVED, subject to the terms and conditions of the policy, certain policies may require an endorsement. A statement on this certificate does not confer rights to the certificate holder in lieu of such endorsement(s).

PRODUCER The Hilb Group New England, LLC 2000 Chapel View Blvd Suite 240 Cranston RI 02920		CONTACT NAME: Laura Routzahn PHONE (A/C, No, Ext): (800) 232-0582 FAX (A/C, No): (888) 505-9300 E-MAIL ADDRESS: lroutzahn@hilbgroup.com	
		INSURER(S) AFFORDING COVERAGE	
		INSURER A: Harleysville Preferred Insurance Co	NAIC # 35696
		INSURER B: Harleysville Insurance Company	23582
		INSURER C: Harleysville Worcester Insurance Co	26182
		INSURER D: Evanston Insurance Company	35378
		INSURER E:	
		INSURER F:	
INSURED Consys Inc 2502 Martin Luther King Ave, SE Washington DC 20020			

COVERAGES**CERTIFICATE NUMBER:** CL24102461448**REVISION NUMBER:**

THIS IS TO CERTIFY THAT THE POLICIES OF INSURANCE LISTED BELOW HAVE BEEN ISSUED TO THE INSURED NAMED ABOVE FOR THE POLICY PERIOD INDICATED. NOTWITHSTANDING ANY REQUIREMENT, TERM OR CONDITION OF ANY CONTRACT OR OTHER DOCUMENT WITH RESPECT TO WHICH THIS CERTIFICATE MAY BE ISSUED OR MAY PERTAIN, THE INSURANCE AFFORDED BY THE POLICIES DESCRIBED HEREIN IS SUBJECT TO ALL THE TERMS, EXCLUSIONS AND CONDITIONS OF SUCH POLICIES. LIMITS SHOWN MAY HAVE BEEN REDUCED BY PAID CLAIMS.

INSR LTR	TYPE OF INSURANCE	ADDL INSD	SUBR WVD	POLICY NUMBER	POLICY EFF (MM/DD/YYYY)	POLICY EXP (MM/DD/YYYY)	LIMITS	
A	<input checked="" type="checkbox"/> COMMERCIAL GENERAL LIABILITY	Y	Y	MPA00000075576D	10/04/2024	10/04/2025	EACH OCCURRENCE	\$ 1,000,000
	<input type="checkbox"/> CLAIMS-MADE <input checked="" type="checkbox"/> OCCUR						DAMAGE TO RENTED PREMISES (Ea occurrence)	\$ 100,000
							MED EXP (Any one person)	\$ 5,000
							PERSONAL & ADV INJURY	\$ 1,000,000
	GEN'L AGGREGATE LIMIT APPLIES PER:						GENERAL AGGREGATE	\$ 2,000,000
	<input type="checkbox"/> POLICY <input checked="" type="checkbox"/> PRO-JECT <input type="checkbox"/> LOC						PRODUCTS - COMP/OP AGG	\$ 2,000,000
	OTHER:						Installation Floater	\$ 2,000,000
B	<input checked="" type="checkbox"/> AUTOMOBILE LIABILITY	Y	Y	BA 00000052452D	10/04/2024	10/04/2025	COMBINED SINGLE LIMIT (Ea accident)	\$ 1,000,000
	<input checked="" type="checkbox"/> ANY AUTO						BODILY INJURY (Per person)	\$
	<input type="checkbox"/> OWNED AUTOS ONLY <input type="checkbox"/> SCHEDULED AUTOS						BODILY INJURY (Per accident)	\$
	<input type="checkbox"/> HIRED AUTOS ONLY <input type="checkbox"/> NON-OWNED AUTOS ONLY						PROPERTY DAMAGE (Per accident)	\$
							PIP-Basic	\$ 100,000
C	<input checked="" type="checkbox"/> UMBRELLA LIAB	Y	Y	CMB00000064793D	10/04/2024	10/04/2025	EACH OCCURRENCE	\$ 8,000,000
	<input type="checkbox"/> EXCESS LIAB						AGGREGATE	\$ 8,000,000
	<input type="checkbox"/> DED <input checked="" type="checkbox"/> RETENTION \$ 0							\$
B	WORKERS COMPENSATION AND EMPLOYERS' LIABILITY	N/A	Y	WC00000064792D	10/04/2024	10/04/2025	<input checked="" type="checkbox"/> PER STATUTE <input type="checkbox"/> OTH-ER	
	ANY PROPRIETOR/PARTNER/EXECUTIVE OFFICER/MEMBER EXCLUDED? (Mandatory in NH)						E.L. EACH ACCIDENT	\$ 1,000,000
	If yes, describe under DESCRIPTION OF OPERATIONS below						E.L. DISEASE - EA EMPLOYEE	\$ 1,000,000
							E.L. DISEASE - POLICY LIMIT	\$ 1,000,000
D	Excess Liability	Y	Y	XOBW9816023	10/04/2024	10/04/2025	\$2,000,000 OCC	\$2,000,000 AGG

DESCRIPTION OF OPERATIONS / LOCATIONS / VEHICLES (ACORD 101, Additional Remarks Schedule, may be attached if more space is required)



CO No. 006_GF-2020-C-0036; Replace Natural Grass Athletic Field w/Synthetic Turf 4200 Connecticut Ave., NW, Washington, DC 20008
 University of the District of Columbia is Additional Insured with respect to work or services performed under the contract. Insurance is Primary and Non-Contributory. No other insurance from any other entity shall apply before the above insurance coverage and limits of liability are exhausted. A Waiver of Subrogation applies in favor of the University of the District of Columbia for all claims made against the District, its officers, directors, agents, and employees.

CERTIFICATE HOLDER**CANCELLATION**

University of the District of Columbia Office of Contracting and 4200 Connecticut Ave NW Washington DC 20008	SHOULD ANY OF THE ABOVE DESCRIBED POLICIES BE CANCELLED BEFORE THE EXPIRATION DATE THEREOF, NOTICE WILL BE DELIVERED IN ACCORDANCE WITH THE POLICY PROVISIONS. AUTHORIZED REPRESENTATIVE 
--	--

© 1988-2015 ACORD CORPORATION. All rights reserved.

Payment and Performance Bonds

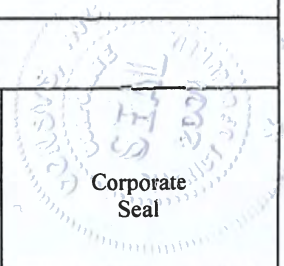
PERFORMANCE BOND (CONSTRUCTION) <small>(See Instructions on Reverse)</small>		Date Bond Executed (Must be same or later than date of Contract) October 7, 2020		
PRINCIPAL (Legal Name and Address) Consys, Inc. 732 Kennedy Street, NW Washington, DC 20011	TYPE OF ORGANIZATION ("x")			
	<input type="checkbox"/> INDIVIDUAL	<input type="checkbox"/> PARTNERSHIP		
	<input type="checkbox"/> JOINT VENTURE	<input checked="" type="checkbox"/> CORPORATION		
STATE OF INCORPORATION DC				
SURETY (IES) (Name(s) and Address(es)) North American Specialty Insurance Company 1450 American Lane, Suite 1100 Schaumburg, IL 60173	PENAL SUM OF BOND			
	MILLION(S)	THOUSAND(S)	HUNDRED(S)	CENTS
	4	144	976	80
	CONTRACT DATE		CONTRACT NUMBER	
		GF-2020-B-0036		
<p>KNOW ALL MEN BY THESE PRESENTS. That we, the Principal and Surety(ies) hereto are firmly bounds to the District of Columbia Government, a municipal corporation, hereinafter called the District, in the above penal sum for the payment of which we bind ourselves, our heirs, executors, and successors, "jointly" and "severally"; Provided that, where the Surety(ies) are corporations acting as co-sureties, we, the Sureties, bind ourselves in such sum "jointly" and "severally" only for the purpose of allowing a joint action or actions against any or all of us, and for all other purposes each Surety binds itself, jointly and severally with the Principal, for the payment of such sum only as is set forth opposite the name of such Surety, but if no limit of liability is indicated, the limit of liability shall be the full amount of the penal sum.</p> <p>THE CONDITION OF THIS OBLIGATION IS SUCH, that whereas the Principal entered into the Contract identified above.</p> <p>NOW THEREFORE, if the Principal shall well and truly perform and fulfill all undertakings, covenants, terms and condition, and agreements of the Contract during the original term of the Contract and any extension thereof that may be granted by the District with or without notice to the Surety, and during the life of guaranty required under the Contract, and shall also well and truly perform and fulfill all the undertakings, covenants, terms, conditions and agreements of any duly authorized modifications of the Contract that may hereafter be made, notice of which modifications to the Surety being hereby waived, and shall save harmless and indemnify the District from any and all claims, delays, suits, costs, charges, damages, counsel fees, judgments and decrees to which the District may be subjected at any time on account of any infringement by the Principal of letters, patents, or copyrights, unless otherwise specifically stipulated in the Contract or on account of any injury to persons or damage to property or premises that occur as a result of any act or omission of Principal in connection with the prosecution of the work under the Contract and shall pay the same, then the above obligation shall be void; otherwise to remain in full force and virtue.</p> <p>IN WITNESS WEHREOF, the Principal and Surety(ies) have executed this performance bond and have affixed their seals on the date set forth above.</p>				
PRINCIPAL				
1. Signature  (Seal)	1. Attest 		 Corporate Seal	
Name & Title (typed) RAJ SHUKLA, VICE-PRES.	Name & Title (typed) VIJAY KASIMSETTY, VP			
2. Signature (Seal)	2. Attest		Corporate Seal	
Name & Title (typed)				

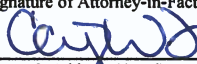
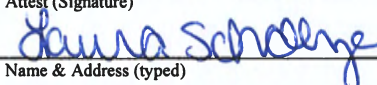
SURETY (IES)			
1. Name & Address (typed) North American Specialty Insurance Company 1450 American Lane, Suite 1100 Schaumburg, IL 60173		State of Inc. NH	Liability Limit \$4,144,976.80
Signature of Attorney-in-Fact 		Attest (Signature) 	
Name & Address (typed) Courtney W. Judge, Attorney-In-Fact 303 International Circle, Suite 160, Hunt Valley, MD 21030		Name & Address (typed) Laura Scholze, Assistant 303 International Circle, Suite 160, Hunt Valley, MD 21030	
1. Name & Address (typed)		State of Inc.	Liability Limit
Signature of Attorney-in-Fact		Attest (Signature)	
Name & Address (typed)		Name & Address (typed)	
BOND PREMIUM			
Rate Per Thousand 12.24/9.57/7.70	Total Premium \$37,926.00	Name & Address of Agency or Agent Receiving Commission RSC Ins Brokerage Inc 303 International Circle, Suite 160, Hunt Valley, MD 21030	
Approved By:			
_____ Mary Ann Harris Chief Contracting Officer		or	_____ Eddie Whitaker Contracting Officer
INSTRUCTIONS			
<p>1. The full legal name and business address of the Principal shall be inserted in the space designated "Principal" on the face of this form. The bond shall be signed by the authorized person signing the Contract. When such person signing is other than the President or Vice-President of a corporation, evidence of authority shall be furnished. Such evidence shall be in the form of either an Extract of Minutes of a meeting of the Board of Directors, or Extract of Bylaws, certified by the Corporate Secretary, or Assistant Secretary and with Corporate Seal affixed thereto.</p> <p>2. Corporations executing the bond as sureties shall be among those appearing on the U.S. Treasury Department's list of approved sureties and shall be acting within the limitations set forth therein, and shall also be licensed by the Insurance Administration, Department of Consumer and Regulatory Affairs, to do business in the District of Columbia. The surety shall (1) insert on the bond form the name and addresses of the agency receiving the commission; and (2) attach an adequate Power-of-Attorney for each representative signing the bond.</p> <p>3. Corporations executing the bond shall affix their Corporate Seals. Individuals shall sign full first name, middle initial and last name opposite the word "seal"; two witnesses shall sign and include their addresses, under the word "witness". If executed in Maine or New Hampshire, an adhesive seal shall be affixed.</p> <p>4. The name of each person signing this performance bond shall be typed in the space provided.</p>			

PAYMENT BOND (CONSTRUCTION) <small>(See Instructions on Reverse)</small>		Date Bond Executed (Must be same or later than date of Contract) October 7, 2020			
PRINCIPAL (Legal Name and Address) Consys, Inc. 732 Kennedy Street, NW Washington, DC 20011		TYPE OF ORGANIZATION ("x")			
		<input type="checkbox"/> INDIVIDUAL <input type="checkbox"/> PARTNERSHIP <input type="checkbox"/> JOINT VENTURE <input checked="" type="checkbox"/> CORPORATION			
		STATE OF INCORPORATION DC			
SURETY (IES) (Name(s) and Address(es)) North American Specialty Insurance Company 1450 American Lane, Suite 1100 Schaumburg, IL 60173		PENAL SUM OF BOND			
		MILLION(S) 4	THOUSAND(S) 144	HUNDRED(S) 976	CENTS 80
		CONTRACT DATE		CONTRACT NUMBER GF-2020-B-0036	
<p>KNOW ALL MEN BY THESE PRESENTS. That we, the Principal and Surety(ies) hereto are firmly bounds to the District of Columbia Government, a municipal corporation, hereinafter called the District, in the above penal sum for the payment of which we bind ourselves, our heirs, executors, and successors, "jointly" and "severally" only for the purpose of allowing a joint action or actions against any or all of us, and for all other purposes each Surety binds itself, jointly and severally with the Principal, for the payment of such sum only as is set forth opposite the name of such Surety, but if no limit of liability is indicated, the limit of liability shall be the full amount of the penal sum.</p> <p>THE CONDITION OF THIS OBLIGATION IS SUCH, that whereas the Principal entered into the Contract identified above.</p> <p>NOW, THEREFORE, if the Principal shall promptly make payment to all persons supplying labor and material in the prosecution of the work provided for in the Contract, and any and all duly authorized modifications of the Contract that may hereafter be made, notice of which modifications to the Surety(ies) being hereby waived, then the above obligation shall be void; otherwise to remain in full force and virtue.</p> <p>IN WITNESS WEHREOF, the Principal and Surety (ies) have executed this performance bond and have affixed their seals on the date set forth above.</p>					
PRINCIPAL					
1. Signature (Seal)		1. Attest 			
Name & Title (typed) RAJ SHUKLA, VICE-PRES.		Name & Title (typed) VIJAY KASIMSETTY, VICE-PRES			
2. Signature (Seal)		2. Attest			
Name & Title (typed)					
		Corporate Seal			

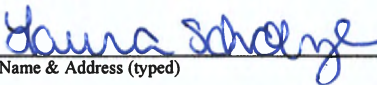
SURETY (IES)			
1. Name & Address (typed) North American Specialty Insurance Company 1450 American Lane, Suite 1100 Schaumburg, IL 60173		State of Inc. NH	Liability Limit \$4,144,976.80
Signature of Attorney-in-Fact 		Attest (Signature) 	
Name & Address (typed) Courtney W. Judge, Attorney-In-Fact 303 International Circle, Suite 160, Hunt Valley, MD 21030		Name & Address (typed) Laura Scholze, Assistant 303 International Circle, Suite 160, Hunt Valley, MD 21030	
1. Name & Address (typed)		State of Inc.	Liability Limit
Signature of Attorney-in-Fact		Attest (Signature)	
Name & Address (typed)		Name & Address (typed)	
BOND PREMIUM			
Rate Per Thousand 12.24/9.57/7.70	Total Premium \$37,926.00	Name & Address of Agency or Agent Receiving Commission RSC Ins Brokerage Inc 303 International Circle, Suite 160, Hunt Valley, MD 21030	
Approved By:			
<div style="display: flex; justify-content: space-around; align-items: center;"> <div style="text-align: center;"> <hr style="width: 100%;"/> <p>Mary Ann Harris Chief Contracting Officer</p> </div> <div style="text-align: center;"> <p>or</p> <hr style="width: 100%;"/> <p>Eddie Whitaker Contracting Officer</p> </div> </div>			
INSTRUCTIONS			
<ol style="list-style-type: none"> 1. The full legal name and business address of the Principal shall be inserted in the space designated "Principal" on the face of this form. The bond shall be signed by the authorized person signing the Contract. When such person signing is other than the President or Vice-President of a corporation, evidence of authority shall be furnished. Such evidence shall be in the form of either an Extract of Minutes of a meeting of the Board of Directors, or Extract of Bylaws, certified by the Corporate Secretary, or Assistant Secretary and with Corporate Seal affixed thereto. 2. Corporations executing the bond as sureties shall be among those appearing on the U.S. Treasury Department's list of approved sureties and shall be acting within the limitations set forth therein, and shall also be licensed by the Insurance Administration, Department of Consumer and Regulatory Affairs, to do business in the District of Columbia. The surety shall (1) insert on the bond form the name and addresses of the agency receiving the commission; and (2) attach an adequate Power-of-Attorney for each representative signing the bond. 3. Corporations executing the bond shall affix their Corporate Seals. Individuals shall sign full first name, middle initial and last name opposite the word "seal"; two witnesses shall sign and include their addresses, under the word "witness". If executed in Maine or New Hampshire, an adhesive seal shall be affixed. 4. The name of each person signing this payment bond shall be typed in the space provided. 			

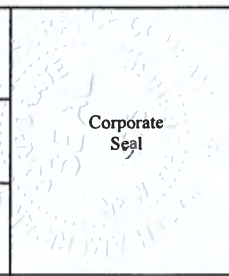

SWISS RE CORPORATE SOLUTIONS

SWISS RE CORPORATE SOLUTIONS AMERICA INSURANCE CORPORATION ("SRCSAIC")
SWISS RE CORPORATE SOLUTIONS PREMIER INSURANCE CORPORATION ("SRCSPIC")
WESTPORT INSURANCE CORPORATION ("WIC")

GENERAL POWER OF ATTORNEY

KNOW ALL MEN BY THESE PRESENTS, THAT SRCSAIC, a corporation duly organized and existing under laws of the State of Missouri, and having its principal office in the City of Kansas City, Missouri, and SRCSPIC, a corporation organized and existing under the laws of the State of Missouri and having its principal office in the City of Kansas City, Missouri, and WIC, organized under the laws of the State of Missouri, and having its principal office in the City of Kansas City, Missouri, each does hereby make, constitute and appoint:

THOMAS W. WHIPPLE, BRIAN C. WHIPPLE, JOHN T. WHIPPLE, DOUGLAS J. DIXON, LAURA E. SCHOLZE, COURTNEY W. JUDGE, ZACHARY D. DIXON, MAI-LING RODRIGUEZ, LAUREN K. BURKHART, JUSTIN SILVA and MELODY GIST

JOINTLY OR SEVERALLY

Its true and lawful Attorney(s)-in-Fact, to make, execute, seal and deliver, for and on its behalf and as its act and deed, bonds or other writings obligatory in the nature of a bond on behalf of each of said Companies, as surety, on contracts of suretyship as are or may be required or permitted by law, regulation, contract or otherwise, provided that no bond or undertaking or contract or suretyship executed under this authority shall exceed the amount of:

TWO HUNDRED MILLION (\$200,000,000.00) DOLLARS

This Power of Attorney is granted and is signed by facsimile under and by the authority of the following Resolutions adopted by the Boards of Directors of both SRCSAIC and SRCSPIC at meetings duly called and held on the 18th of November 2021 and WIC by written consent of its Executive Committee dated July 18, 2011.

"RESOLVED, that any two of the President, any Managing Director, any Senior Vice President, any Vice President, the Secretary or any Assistant Secretary be, and each or any of them hereby is, authorized to execute a Power of Attorney qualifying the attorney named in the given Power of Attorney to execute on behalf of the Corporation bonds, undertakings and all contracts of surety, and that each or any of them hereby is authorized to attest to the execution of any such Power of Attorney and to attach therein the seal of the Corporation; and it is

FURTHER RESOLVED, that the signature of such officers and the seal of the Corporation may be affixed to any such Power of Attorney or to any certificate relating thereto by facsimile, and any such Power of Attorney or certificate bearing such facsimile signatures or facsimile seal shall be binding upon the Corporation when so affixed and in the future with regard to any bond, undertaking or contract of surety to which it is attached."



By Erik Janssens, Senior Vice President of SRCSAIC & Senior Vice President of SRCSPIC & Senior Vice President of WIC

By Gerald Jagrowski, Vice President of SRCSAIC & Vice President of SRCSPIC & Vice President of WIC

IN WITNESS WHEREOF, SRCSAIC, SRCSPIC, and WIC have caused their official seals to be hereunto affixed, and these presents to be signed by their authorized officers

this 12TH day of JANUARY, 20 23

State of Illinois County of Cook

Swiss Re Corporate Solutions America Insurance Corporation
Swiss Re Corporate Solutions Premier Insurance Corporation
Westport Insurance Corporation

On this 12TH day of JANUARY, 20 23, before me, a Notary Public personally appeared Erik Janssens, Senior Vice President of SRCSAIC and Senior Vice President of SRCSPIC and Senior Vice President of WIC and Gerald Jagrowski, Vice President of SRCSAIC and Vice President of SRCSPIC and Vice President of WIC, personally known to me, who being by me duly sworn, acknowledged that they signed the above Power of Attorney as officers of and acknowledged said instrument to be the voluntary act and deed of their respective companies.



Christina Manisco, Notary

I, Jeffrey Goldberg, the duly elected Senior Vice President and Assistant Secretary of SRCSAIC and SRCSPIC and WIC, do hereby certify that the above and foregoing is a true and correct copy of a Power of Attorney given by said SRCSAIC and SRCSPIC and WIC, which is still in full force and effect.

IN WITNESS WHEREOF, I have set my hand and affixed the seals of the Companies this 16 day of April, 20 25

Jeffrey Goldberg, Senior Vice President & Assistant Secretary of SRCSAIC and SRCSPIC and WIC

Clean Hands Certificate



Date of Notice: April 14, 2025

Notice Number: L0014061058

CONSYS INC
2502 MARTIN LUTHER KING JR AVE SE
WASHINGTON DC 20020-5210

FEIN: **-***8636
Case ID: 18579318



CERTIFICATE OF CLEAN HANDS

As reported in the Clean Hands system, the above referenced individual/entity has no outstanding liability with the District of Columbia Office of Tax and Revenue or the Department of Employment Services. As of the date above, the individual/entity has complied with DC Code § 47-2862, therefore this Certificate of Clean Hands is issued.

TITLE 47. TAXATION, LICENSING, PERMITS, ASSESSMENTS, AND FEES
CHAPTER 28 GENERAL LICENSE
SUBCHAPTER II. CLEAN HANDS BEFORE RECEIVING A LICENSE OR PERMIT
D.C. CODE § 47-2862 (2006)
§ 47-2862 PROHIBITION AGAINST ISSUANCE OF LICENSE OR PERMIT

Authorized By Melinda Jenkins

Branch Chief, Collection and Enforcement Administration

To validate this certificate, please visit MyTax.DC.gov. On the MyTax DC homepage, click the "Validate a Certificate of Clean Hands" hyperlink under the Clean Hands section.

Fiscal Impact Statement

TO: The Board of Trustees
FROM: Managing Director of Finance *David A. Franklin*
DATE: June 10, 2025
SUBJECT: Change Order No. 6: Agreement for “Replace Natural Grass Athletic Field with Synthetic Turf” Project

Conclusion

It has been concluded that the University has sufficient funding in the FY2025 Capital Construction Budget to fund the \$1,531,652.71 costs for Change Order No. 6 on the “Replace Natural Grass Athletic Field with Synthetic Turf” project at the Van Ness Campus.

Background

The Athletic Field project replaced the existing grass athletic field with an artificial turf field with markings for NCAA soccer and lacrosse. This Change Order addresses several scope modifications to improve usability and student safety by relocating the emergency vehicle access to the south side of field, increasing the new turf field size. This change also includes additional General Contractor costs to provide value-added modifications and address additional unforeseen site conditions that were beyond General Contractors’ control.

Risks & Assumptions

Based on the information provided there are no known risks to the University at this time.